

MAXIMUM REACH ENTERPRISES

1853 Wellington Court
Henderson, NV 89014
Ph: 702 547 1564
kent.goodman @ cox.net
www.maximumreach.com

21 July 2014

SAFETY IN THE DESIGN AND THE EXECUTION OF RIGGING OPERATIONS

I am a retired rigging engineer and I want to quickly give you a little background on how I became a rigging engineer. My Father worked construction as a mechanic, dozer, shovel and backhoe operator. It was natural then that my brothers and I followed in his footsteps. I learned how to operate a dozer, shovel, scraper and loader. But the piece of equipment I really wanted to learn how to operate was a crane. Local 428 in Phoenix finally sent me out to oil on a 25-ton Northwest truck crane. I oiled for several operators and finally after about 3 years got to be the operator. I really enjoyed being a crane operator and it paid well, so I could have easily spent my working years as one. But as I sat on the crane pouring a bridge deck, I wondered why the engineers had used 8" of concrete for the deck instead of 10", or why the support beams were thicker at the ends than at the middle, or why the rebar was bent down in the bottom of the forms at the center of the span and bent up at the ends. All of these questions kept me wanting to know the answers.

So, I talked my wife Chon into going back to work and I enrolled in the Civil Engineering program at ASU in Tempe. At the time I was 24 years old and had two hungry kids, a daughter and son who were 4 and 2 years old respectively. I went the first year but then had to drop out of school the next semester to replenish our kitty. This went on through out my time in school so that it took me 9 years to get my degree. Chon said I crammed a 5-year curriculum into 9 years. Chon also said that nobody wanted to hire a crane operating civil engineer. This is the only time that she has been wrong about anything in the 60 years that we have been married, because as I began interviewing with different construction companies, I found that they did want someone with field experience and with an engineering degree.

I received some very good offers and finally decided to go to work for the Fluor Corporation in Irvine, CA in their rigging engineering department. Now, my dream had come true. I was ecstatic. I was utilizing my crane operating experience and my engineering to do what I had been dreaming of doing for so many years. Years earlier, our Dad often told us boys that we should always try to be the best that we could be no matter what we were doing, ie, if we were ditch diggers in a ditch, we should be the best ditch diggers in the ditch and if we tried hard our passion would shine through and we would stick out like a sour thumb. And pretty soon we would be up on the bank and would be the boss of the ditch diggers in the ditch. So now I was being trained as a rigging engineer and remembering Dad words of advice, I wanted to be the best rigging engineer I could be. So I worked hard, studied hard, listened and learned from my fellow engineers and from my supervisor and went to the field as often as I could. It wasn't too

many years until I became the head of the rigging department in Irvine and not too many years after that, I became the first rigging manager over all of Fluor's rigging offices worldwide. Because I have been passionate about my work, I have enjoyed my working days so much that I can say that I didn't have to many days that I didn't enjoy going to work. I tell you this and also other examples to follow, not to brag but it is just fact.

I want to share with you what was one of the high lights of my rigging career. The three photos below show the erecting of a crude column 32 ft. in ϕ x 285 ft. high x 1,169 tons. I supervised the design of this lift in Irvine, went to the field and helped convert the American 11320 lift cranes into the guy derrick configuration, helped set up the guy derricks and guy wires, operated the guy derrick in the foreground in setting the crude column (see second photo), and then helped reconfigure the cranes back into lift cranes. Each guy derrick had a capacity of 600 tons.

Three Photos Of The Crude Column Lift:



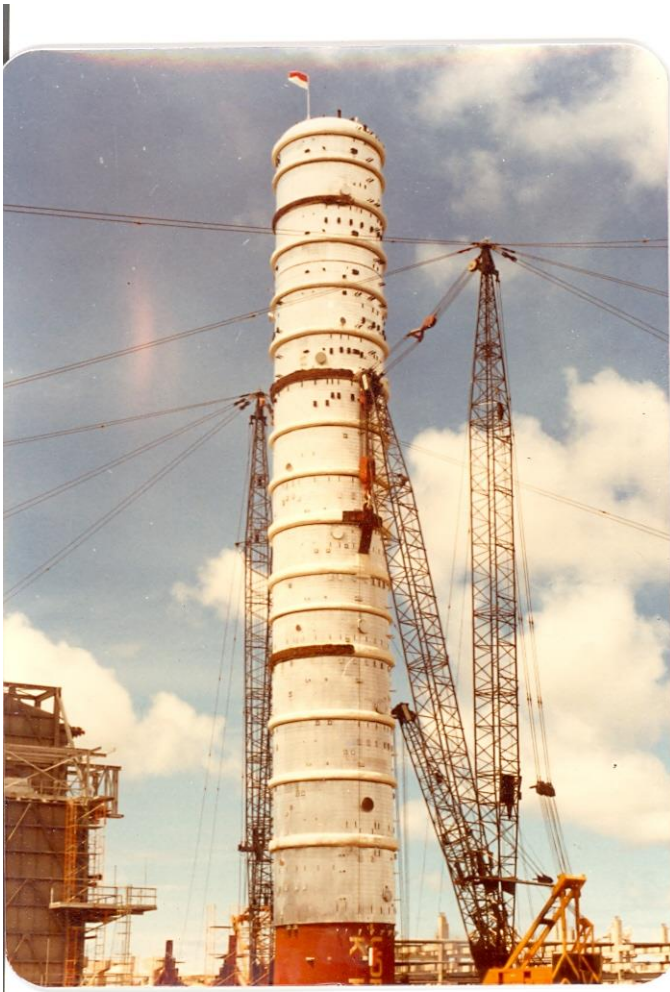

Notice in the second photo above that there are a lot of people shown in and around the crude column lift where they shouldn't be. This is because we had a main drum failure on the guy derrick in the back ground and the crude column was held in this position in the air for three days. The drawing below shows the details of the lagging for the main drum. AH&D used lagging around the drum shafts so that the crane owner had the option of using different diameters of hoist line, ie, 1.25" for crane work or 1.38" for dragline work, etc. The flanges of the lagging were bolted to the flanges of the drum with 28 high strength bolts. Note the 1" space between the two halves of the lagging. The failure occurred because the high tension in the hoist line caused the lagging to deflect until the two halves touched in the middle and took the shape of an hour glass. This caused the flanges on the lagging to pull away from the flanges on the drum until the top bolts in each end of each half broke. We tied off the hoist line in two places, removed the rest of the hoist line from the drum, replaced all of the 28 bolts, welded a 1" flat bar in the gap on each side of the two halves of the lagging, cut the hoist line so that there would be five wraps on the lagging and then reinstalled it. We then did the same to the other guy derrick. Then we completed the lift.

The cause of this near miss was a design failure on the part of AH&D. They designed the lagging based on the drum being about half full when the full load was seen by it. But with erection of the crude column, the side lifting lugs were located about 5' above the center of gravity. This meant that each crane and main drum was seeing about 575 tons at initial pick. To make the lift work, we started the lift with 5 wraps of hoist line on each drum. Therefore, the lagging didn't have 6 layers of wire rope to distribute out the load, so the two halves of the lagging pulled together like an hour glass as explained above.

AMERICAN HOIST & DERRICK CO.
ST. PAUL, MINNESOTA 55107

DRUM SPLIT LAGGING INSTALLATION
MODEL 11310
1100 SERIES CRANES

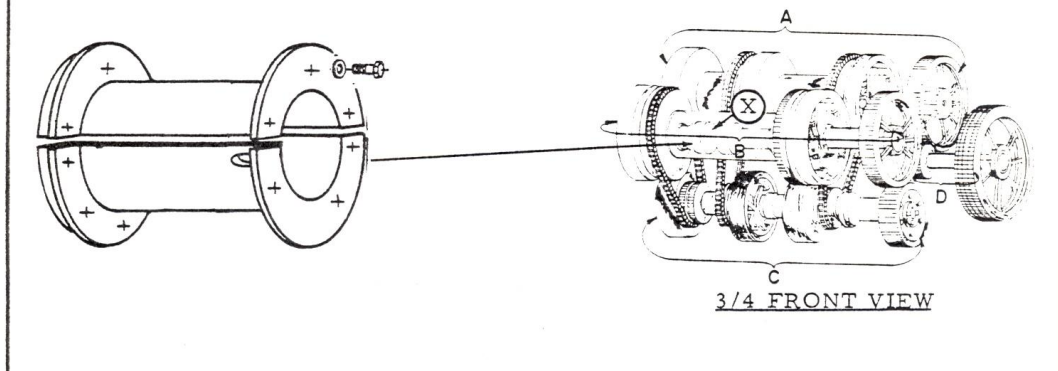

In addition to the above lift, I have had the opportunity to operate all of the heavy lift cranes that I have made lifts with. At least, I got to play around with them before or after the lifts.

Guy Derrick Lifts:

Several examples in my presentation will be about the American Guy Derricks even though they are not being used much anymore, but the material will still be applicable to the cranes we are using today, ie, the equipment changes but the problems seem to always be about the same.

I do want to say that once an American Guy Derrick is set up with all of the guy lines tensioned up, it is the lift safest you can make. This is because during lifting the crane does not see any tipping, ie, everything is in structural. Fluor made well over 200 guy derrick lifts, more than the combined lifts of all the other contractors in the world.

PASSION FOR RIGGING:

I would encourage you to become passionate about your work, ie, if you are an oiler, set your goal high to say first becoming a crane operator and then aim for the manager's position, etc. As my Dad said, if you are passionate and work hard, you will stand out like a sore thumb. And the promotions will come. Working hard and passion goes hand in hand and one leads to the other. I want to emphasize passion over money because passion in your work will bring you much more contentment and satisfaction than money ever will.

PASSION FOR SAFETY:

The company provides us with all of the safety equipment that we need to keep us from falling, getting eye injuries, head injuries, etc. That is their obligation. But that is only part of the story. We need to be passionate about safety in our everyday work habits. We need to be so passionate about safety that it sort of gets into our DNA and we automatically consider safety in planning and execution every operation we do, ie, we need to say to ourselves, how can we make this operation safer and more efficient. The wonderful thing is that the safer an operation is, the more efficient it is.

Quite often, when I was helping put lifts together in the field, someone would ask if I worked for the site safety department even though I did not wear a red shirt. I was not offended but rather took it as a compliment. The photo below shows a Fluor safety supervisor instructing a contractor's safety supervisor. This photo came about when we were moving some large diameter bullets and the riggers had to get upon them to handle the tie down slings. I asked the contractor's safety supervisor how they were going to tie off. He didn't have a clue. I then called the Fluor safety supervisor for that area and explained my problem. He came to the site and I took the photo as he was kindly and patiently explaining the problem to the contractor's safety supervisor. Kindness and patience can go a long way with safety.



I am a firm believer that Rigging and Safety go together.

RISK:

There are three things about risk that need to be considered:

1. There is risk in everything we do:
For example, while we are at home, while we are driving to work, while we are working, etc. The trick is to reduce or mitigate risk as low as possible.
2. There is unacceptable risk:
Unacceptable risk is injury or loss of life. We must do everything we can to avoid this kind of risk, even declining a project if this cannot be guaranteed. Some of the ways we avoid this kind of risk is to:
 - * Load test all of the rigging gear and lift cranes
 - * Clear the area of all personnel except the rigging crew
 - * Do not upend a vessel into the boom where it will fall on the crane operator
 - * Make sure that the fall direction of the boom will not be into a live unit
 - * Etc.

Eliminating this kind of risk can come at a high cost but must be our first consideration in safety. We need to be able to go home after work to our families. Our rigging designs and operations must provide this.

3. There are acceptable levels of risk:

At home, each of us have established acceptable levels of risk for our families, based primarily on economics, that we feel will protect them and keep them safe from falls, fire, intruders, drowning, etc. On the road, we have an acceptable level of risk by driving prudently and defensively in a vehicle that is well maintained. We can lower our risk even further by buying a Hummer and installing a snowplow on the front of it. It is all in what acceptable risk we want to live with.

At work, there are different levels of acceptable of risk. In most cases, it is economics vs. safety, ie, the engineering department could design a lift pad constructed out of piles and concrete caps where there is no settlement during lifting. This would be low risk for the lift pad. But this is not only very costly, but in most cases not warranted. In contrast, the lift pad could be constructed at a much lower cost by removing say 3 or 4 ft. of topsoil then back filling it with crushed compacted limestone and then laying crane mats on top of it. It could be designed for an allowable settlement of say 0.5" that would result in a higher risk than the piled lift pad. But the allowable settlement might not pose any more risk than other lift factors, ie, weather, condition of the crane, impact, weight determination, CG location, etc. Therefore, in most cases, management will establish what these levels of risk are with input from you guys.

In your daily rigging operations, you can help reduce the acceptable risk by making sure you set on crane mats or load spreaders during lifting, don't lift in the afternoon when there may not be time to complete a lift before dark, don't change the lift plan at the last minute, block the front tumblers, etc. Most crane manufactures publish blocked tumblers ratings, but I recommend that the front tumblers be block for all heavy lifts, not to increase the lifting capacity but to ensure that the lifting capacity shown on the chart is achieved, thus increasing safety and reducing risk.

A lot of the material to reduce risk is already on the jobsite and it only needs to be utilized, ie, crane mats, tag lines, hardwood blocking for tumblers, etc.

SAFETY RECORD OF ENGINEERED LIFTS VS. NON-ENGINEERED LIFTS:

The following percentages may have changed, but just before I retired, the safety Director at Fluor stated that 95 % of all crane accidents happen to "non-engineered lifts". Out of the 5 % left for engineered lifts, 95 % of them occur during set up/tare down.

SAFETY IN DESIGN:

The safety factors for attachment and rigging gear design are well spelled out in OSHA and ASME B30 Standards. It is then left up to the Engineering Department to design everything to code so that in case of an accident, it is defendable in court. Remember, if an accident happens, OSHA will go thru the design very carefully and if they find any thing wrong, even if it had nothing to do with the accident, they will impose fines for every exception. And the company will be lucky if it is not sued for wrongful death in case of a fatality.

For example, you might remember when Dielco was removing a hammerhead tower crane from a new casino in Laughlin, NV. Perini was the prime contractor and provided allowable ground bearing pressures to Dielco. Dielco was using an American 8460 with a long boom and jib to remove the

components of the crane. They were down to removing the turntable, which was the heaviest piece. The plan was to float the turntable, boom it in until it cleared the building and then lower it down on to a lowboy. As the crane operator was booming the load in, the left rear outrigger, as viewed from the operators seat, started sinking. The operator hung on to the load and kept booming up until it cleared the building and then had to drop it as the crane was going over. The boom and jib fell across the main road and the jib fell on a car passing by, killing the male driver. Dielco received a fine from OSHA for not using the correct weight for the turntable. The weight they used was from an older cut sheet and was a few pounds lighter than the cut sheet showed for the actual turntable. They also received a fine because the OSHA inspector asked the crane operator a question and didn't get the answer he expected.

Review Of Our Designs By Others:

Quite often, someone will challenge our design and want to check our calculations. We should be more than willing to let them do so and not be thin skinned or defensive about letting it happen. If someone has a concern, then I feel it is best to stop and check to make sure that the design is sound before continuing with the design or the lift. This would also apply to the field personnel setting up a lift or executing a lift.

For example, in 2003, I went to Nanjing, China as a third party rigging consultant for Fluor to review all of the lifting attachments and rigging plans for the engineered lifts. Unfortunately, the design of the lifting attachments was completed before I got involved so I was reviewing **AS** built drawings. One of the reviews was of the trunnions on a 7m x 92m x 850 Te rectifier. (23' x 302' x 935 ton).

My review showed that the trunnions were overstressed by a factor of 1.5 and the vessel shell was overstressed by a factor of 2 where the doubler pads were welded to it.

The first two photos below show the offloading and transportation of the rectifier.





The next photo shows the dressed out rectifier being upended.



In my report, I stated that lifting the vessel with the trunnions as they were would not cause a failure but would cause serious buckling of the shell in the area of the trunnions but as they would be covered up by the insulation and cladding, the buckling would not show or be discovered until a crew went into the vessel to adjust the trays. They would then find that the tray beams and trays would be buckled, as well the shell around the trunnions. This would be hard to repair with the vessel in the set position.

I gave my review to my Fluor counterpart who in turn issued it to the Contractor who was responsible for setting the rectifier. It turned out that no one from the Contractor's engineering department had checked the design of the Korean fabricator. Most vessel fabricators are very good at fabrication but are not good at designing lifting attachments. The Contractor's field management sent my review to their home office engineering department who agreed with my results. They proposed a fix to the design and I approved it after several revisions. The field then made the modifications to the trunnions while the vessel was being insulated and dressed out. The fix consisted of increasing the diameter and thickness of the doubler pads and adding heavy radial gussets from the trunnions out to the edge of the doubler pads.

At first, the Contractor's field Construction Manager was quite defensive about my review, but after his home office engineering department agreed with it, he actually paid me a visit in my office and thanked me for finding the problem.

The fourth photo shows the right trunnion with the radial gussets which were part of the modification. The rest of the modification is covered up by the insulation and cladding.



How Safe Do Our Designs Need To Be?

The page below shows that our designs need to meet the acceptable limits of risk, but we shouldn't furnish a Cadillac design where a Chevy design is called for in the contract.

SAFETY IN DESIGN

1. How safe do we need to be in our design?
 - a. The design must meet the Industry standards and codes for safety
 - b. The design must meet the job specification for safety
 - c. The design must meet the maximum acceptable risk
 - d. The design must be economical

Therefore the design must be a balance between acceptable risk and economics and still meet the job specification and applicable industry standards and codes for safety.

2. It is our obligation to train and instruct our engineers to provide a design that meets the above balance and not provide a Cadillac design when the job specification only calls for a Chevrolet design.

Stress Strain Curve:

Note that F_y means Yield Stress & $0.6F_y$ is the allowable yield stress for steel design. Also note that actual stress = Load/Area. The graph shows that if we do not exceed the yield point of say a link, that it will return to its normal length when the load is released. But if the load is increased until the link is stressed beyond the yield point, then set occurs and the link will not return to its original shape. If the link is stressed further, then the link will fail.

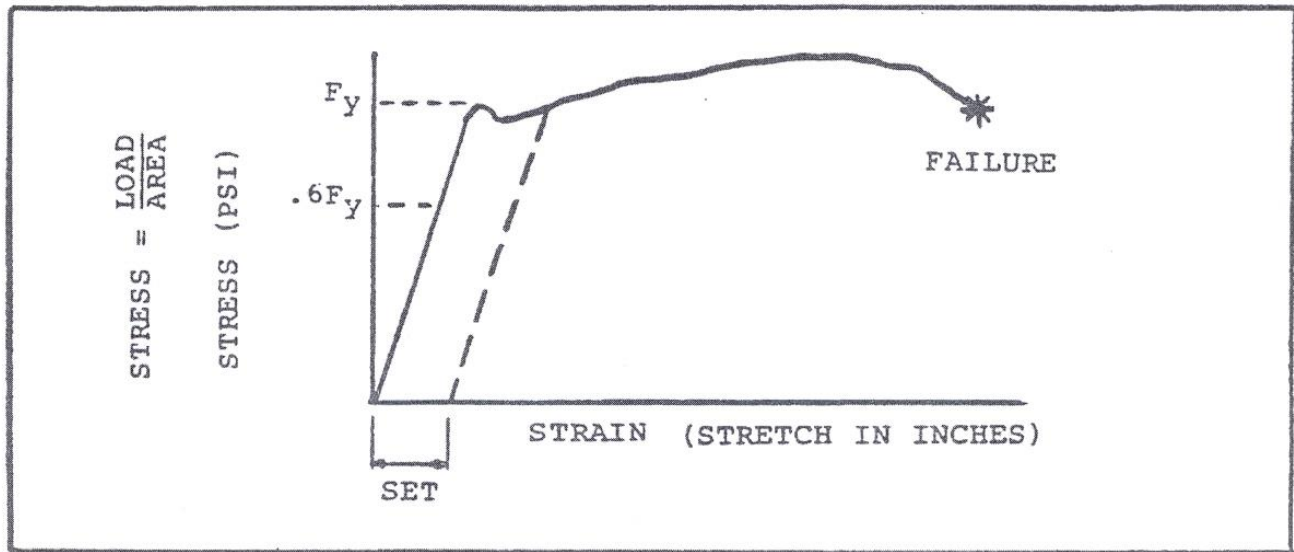

For example, in the sketch below, the link is 1" thick x 5" wide and is being pulled by a 100 kip force and the stress is $100/5 = 20$ ksi. For A36 steel, $F_y = 36$ and $0.6 \cdot F_y = 21.6$ ksi. Therefore, the link will not be overstressed and will return to its original length. But, if we increase the force to 200 kips, then the stress becomes $200/5 = 40$ ksi and the link will have permanent SET in it and won't return to its original length.

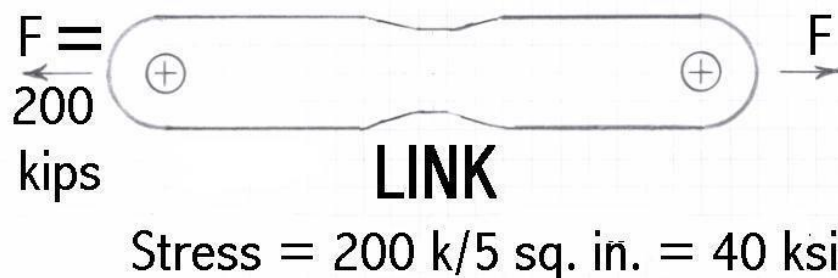
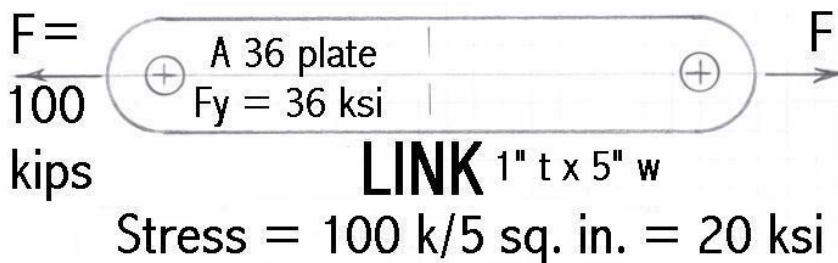

The same goes for a crane boom. Booms are designed for a 2 % side load and tested to a 1 % side load. For example, for a certain length of boom, a certain radius and a 100 % capacity of say 100 ton, the 1 % side load would be a 1-ton horizontal side load located at the boom tip. This could happen if the tail crane pushes/pulls the load block of the lift crane outside the envelope of the boom. It could also happen if the boom is side loaded due to say the lift pad being out of level and the load block drifts outside of the boom. When this happens, the boom cords on the up hillside could become over stressed. If the side load is large enough, the cords on the up hillside will be stretched and will become necked down and the cords on the down hillside will be compressed. This will set up unbalanced stresses in the boom at this point. If they don't fail then, they might sometime in the future when a maximum lift is being made and everyone will wonder why. I recommend that your lift pads be constructed to a level of $\frac{3}{4}$ " in 30'. Then lay your crane mats, walk the lift crane up on the mats and use plywood to level the crane both ways so that it is less than 1/8" using a 4' carpenters level.

So, keep your lift cranes level and within the capacity charts so that overstressing won't occur. Also don't over load your rigging gear for the same reason.

One more word on over loading. I do not believe in load testing a crane to more than 100 % of the capacity chart. Doing so eats in to the Manufactures design for safety. If a crane is being load tested for a specific load and the load is less than 100 % of the chart, then it might be possible to load test the crane to say 1.15*load and still be under 100 % of chart. If a spreader bar must be load tested to say 1.25*SWL, then I recommend that the bar be designed with added capacity so that the load testing will be at 100 % of the SWL.

Because lift pad settlement is the cause of many crane accidents, every endeavor should be taken to make sure that the allowable ground bearing pressure (GBP) of the lift pads is greater than the actual GBP.

The Angle Of The Bottom Slings On A Spreader Bar:

The engineering departments goes too great lengths to make sure that spreader bars are designed for a certain load. The overall spreader length which corresponds to the center to center distance between lifting lugs on the vessel and the inclined sling lengths are listed on the rigging drawing so that the angle of the slings produce the required capacity in the bar. But, sometimes the length of the spreader bar actually used in the field is shorter or longer than the length listed on the rigging drawing. When this happens, the bottom slings are out of plumb toward the center of the bar (in hauled) or out of plumb away from the center of the bar (out hauled). If the bottom slings are in hauled by say 1 degree, the capacity of the spreader bar will increase by approximately 10 % because the bar is being bowed up in the center and this moment will reduce the downward moment. On the other hand, if the slings are out hauled by 1 degree, then the capacity of the spreader bar is reduced by approximately 10 %. If the distance from the bottom lug hole on the bar down to the lifting lug hole is 10', then the horizontal distance for 1 degree is 2.09". This means that the spreader bar cannot be more than 4" longer than the center-to-center distance between lifting lugs in order to keep the reduction below 10 %. So, make every effort to size the inclined slings and the spreader bars for the length listed on the rigging drawing. .

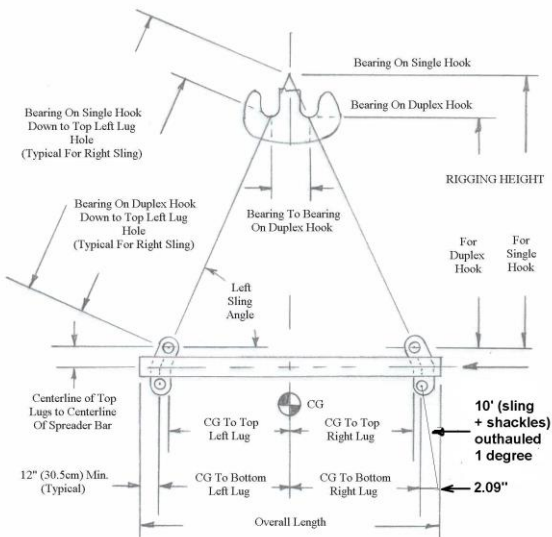

SPREADER BAR WITH LUGS TOP AND BOTTOM

See rigging quiz # 26 for a design of lifting lugs for the sample values

Load Transfer In The Air:

Any operation that includes the transfer of a load in the air should be studied very carefully. If not, an accident can occur similar to the one shown in the sketch. This accident occurred on a project in Brazil and the sketch was made as a lesson learned. As the boom foot was pinned to the mast of the tower crane and crane B was slacked off, the load to crane A went from 14 kips to 30 kips which was about 125 % of the chart and it started to turn over. To save the crane, the operator dropped the hammerhead boom where it was severely damaged when the tip hit the ground.

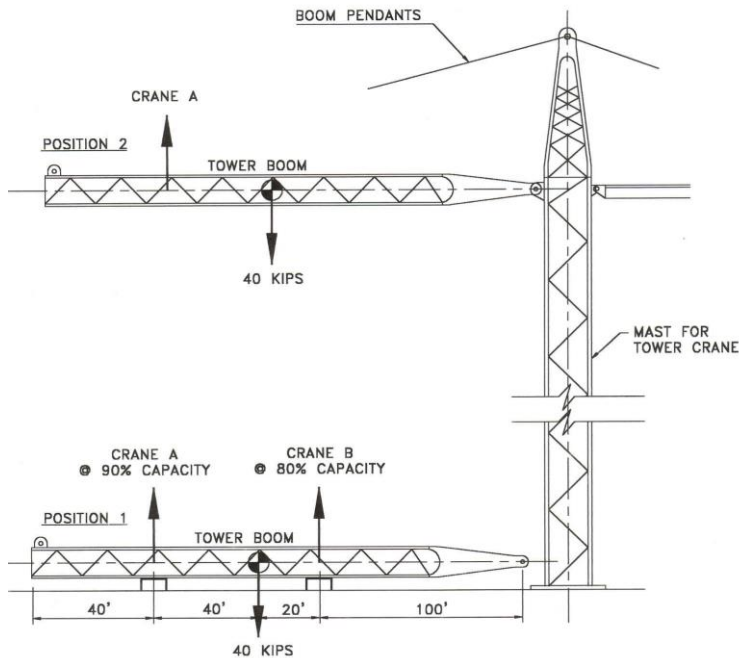

Lifting below the center of gravity:

This photo shows lifting a turbine with 4 lugs located below the center of gravity. I will come back to this topic when I talk about “models”.

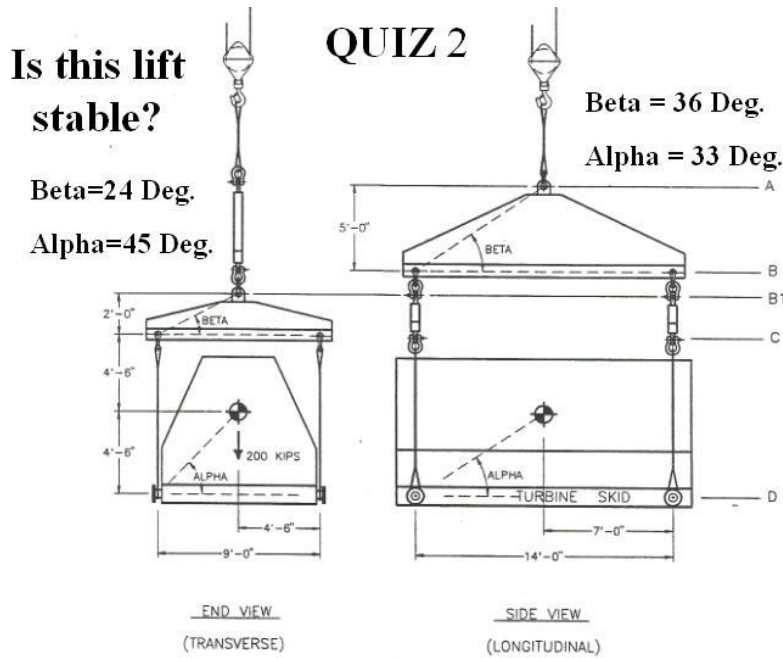

Don't Modify The Crane:

I oiled for an operator named Howard who was a very good operator. At least at the time I thought he was, but looking back on this experience with my current knowledge I can see that he was a very dangerous operator. I will tell you why. He was operating a 25-ton Northwest truck crane and decided that we need more lifting capacity. We didn't have a lifting capacity chart for the crane and just picked until we started tipping. Anyway, he had the master mechanic fabricate two counterweight boxes. We then welded one of them to the back of the house on the crane and the other one on the front of the carrier. We then went to a steel fabricator in Phoenix and got 10 tons of steel punches and put half in each counterweight box. This probably increased the capacity of the crane somewhere between 30 and 35 ton. Mind you, this crane only had one front hook roller and two back hook rollers. At this point, the crane was so back heavy that we could not swing over the side without outriggers for fear of turning over backwards. But boy could we lift. We poured with a 3/4 CY concrete bucket and we could lay the 110' boom down to about 60 degrees with a full bucket. The first photo below shows a counterweight box welded to the back of the house and one to the front of the carrier.

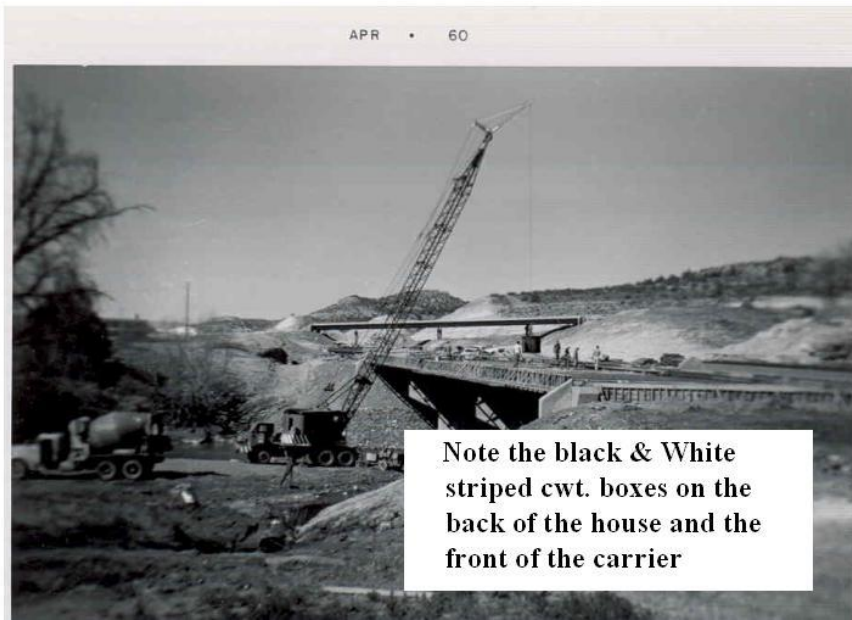

The next photo shows us setting 48 beams that weighed 20 tons each. Before we started setting the beams, Howard positioned 94 of the 96 brass bearing pads on top of the newly installed counterweight box on the back of the crane. This added about 2.5 tons of counterweight to the 10 tons all ready install.

FIELD RIGGING: Setting 48 Prestressed Girders



We first set the beams that were the hardest to reach, ie, the ones between the abutments and the piers and set the close ones last. Each time we set a beam, we lost two bearing pads. I don't know why we didn't have a boom or weldment failure. Of course, this modification was done without the approval of the manufacture.

One of his favorite tricks was to show off when a lot of workmen were watching. He would lift a fairly heavy load, like a bundle of lumber, blow the horn for me to start walking the crane forward and then boom out the load until the front wheels were about 2 feet off the ground. Then when he wanted to make

a turn, he would swing the load over the corner in that direction until the front of the carrier swung around and started making the turn. When the turn was completed, he then centered the load behind the crane and we went on in a straight direction. The onlookers loved the show. I don't know how the walking beams on one side stood up under the weight of the crane and the load. Again, over designed I suppose.

Don't Assume Anything:

This was forcefully brought home to me on one lift we were making where we were tailing with an Am 9310 crawler crane that was at capacity. We hooked up the lift cranes and then spent considerable time pulling the hoist line off the drum of the Am 9310 tail crane with a cat and then slowly spooling it carefully back onto the drum. We then hooked the load block to the tail beam, snugged up on the hoist lines and then went home. At first light the next morning, we fired up both lift cranes and the tail crane and hoisted until the vessel was level at about 12' in the air so that we could remove the two crawler transporters.

Nobody noticed anything was wrong as we were hoisting, but as soon as we started to lower the hoist line on the tail crane, it began to snap and pop. We jumped up on the crane and saw that the hoist line was not spooled correctly; in fact, it was buried down so deep that it looked like a can of worms. If we hadn't needed the headroom, we would have went on with the lift with the basering up in the air. But we needed the basering to be low enough to barely clear the anchor bolts as the vessel was up ended. There was nothing we could do except slowly lower the hoist line until we unspooled the top two layers. You have never heard so much snapping and popping in your life. It was nerve racking but we finally lowered the basering to the right elevation and went on with the lift. Later, we got to checking and found that the night shift had needed the tail crane so they unhooked it from our lift. After using it they hooked it back up with out saying anything and left the wire rope a mess on the drum. We should have checked it out instead of assuming that it was exactly as we left it the night before. DON'T ASSUME. The photo below shows a Beaver who became complacent and thought he knew every way there was to fall a tree. In this case, it looks like he assumed that the tree would fall in the other direction.

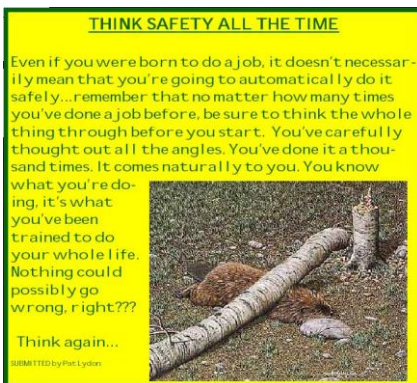

SAFETY AND EFFICIENCY IN DESIGN:

If we look our rigging designs and operations over, we can usually find ways to make them safer and more efficient. I want to show you four items that we designed to make the work more efficient and safer.

1. Lugs for a 400 ton reactor:

This photo shows pads welded to the top head lugs for a 400-ton reactor. These pads were not required for strength but were put there to act as plate spacers to center the shackles on the lugs. As heavy shackle pins can be hard to install thru loose plate spacers and can pinch fingers, we decided to weld the plate spacers to the lug plates to make the operation easier and safer. Note that in general, one-man hour spent in the engineering office can save one crew man-hour in the field. This could translate to a saving of \$1,000 to \$2,000, depending on the size of the crew and equipment being used.

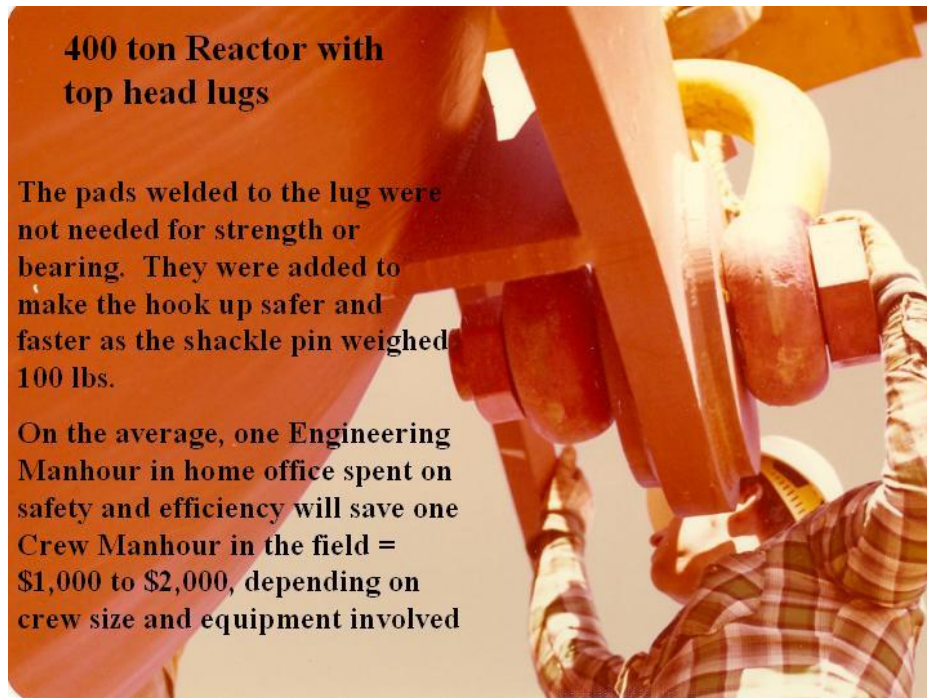

2. Special spreader bars for offloading one 400 ton guard reactor and four 790 ton reactors at Duluth, MN:

Just to give you an idea of the size of the job, the first photo shows the construction of the lift pad and the assembly of the Lampson LTL-1200.

Late September In Duluth

Assembly of crane and construction of lift pad

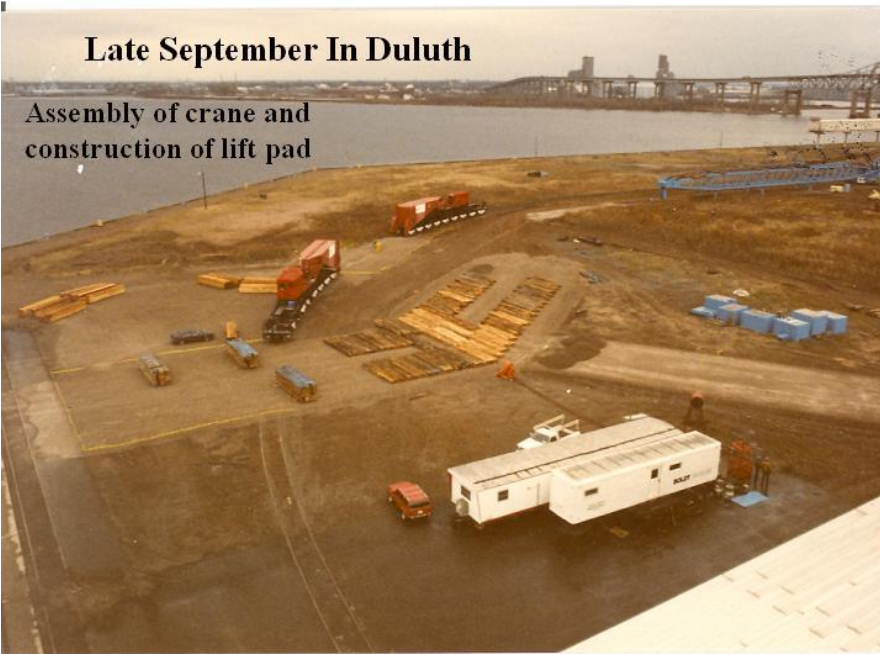

The second photo shows offloading the 400-ton guard reactor, which came in on the deck of the heavy lift ship. The other four reactors were stowed in the hold. Note the spreader bar configuration which was rented as a unit from Lampson. This was not a good set up as the spreader bars were labor intensive to assemble and adjust the length. The eight 2.5" dia. x 102' long slings were a nightmare to handle. We should have cut them into 50' lengths and used shackles to connect them under the bottom of the reactors.

Early
December
In Duluth

The 400
ton guard
reactor
was the
first of the
five
reactors
offloaded

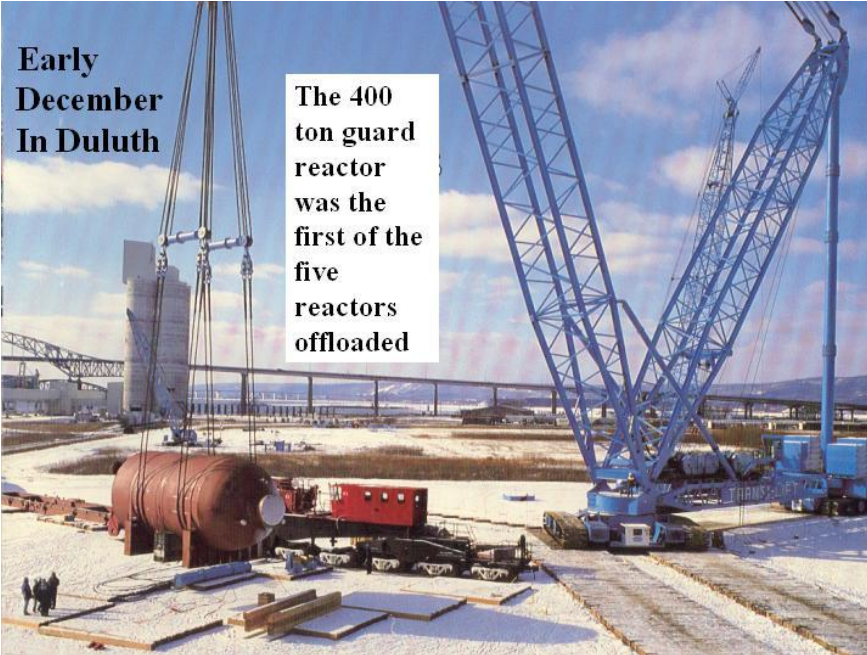

As we were assembling the crane, I kept thinking how hard it was going to be to run the eight slings under the reactors and hook them up to the 85-ton shackles. And then unhook them and pull them back

out again, doing it 16 times. I finally decided to design a special spreader bar and had two made up. It made the hook ups go much smoother and safer.

The third photo shows the details of the spreader bar. Note the lifting lugs located on the back side so the eyes of the slings would lay over for ease of hooking up to the shackles on the opposite spreader bar.

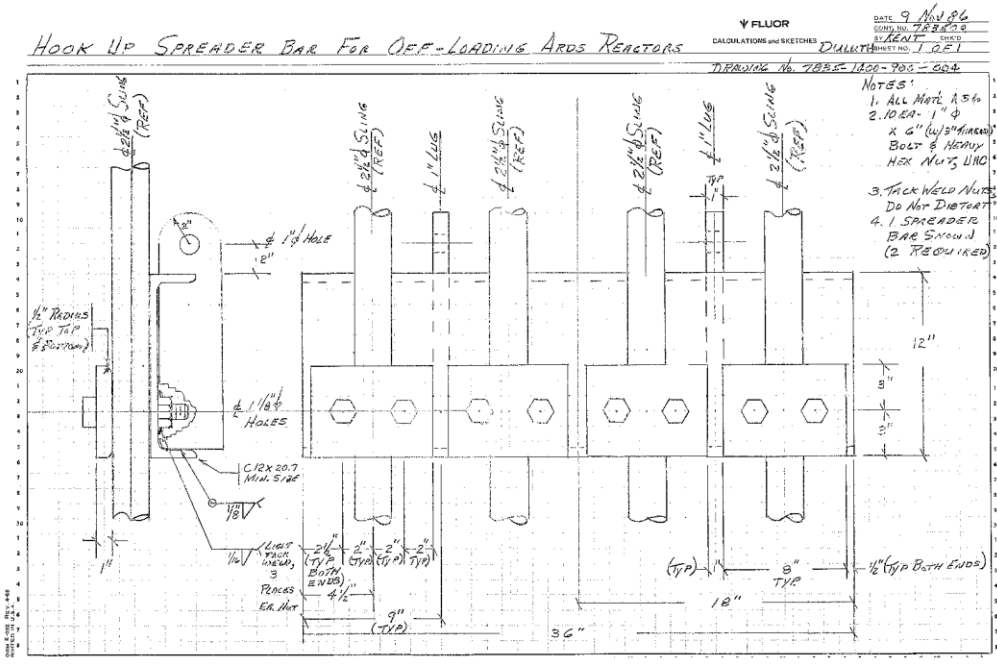

The fourth photo shows three of the reactors offloaded and staged and the ship turned around for offloading the remaining two reactors.

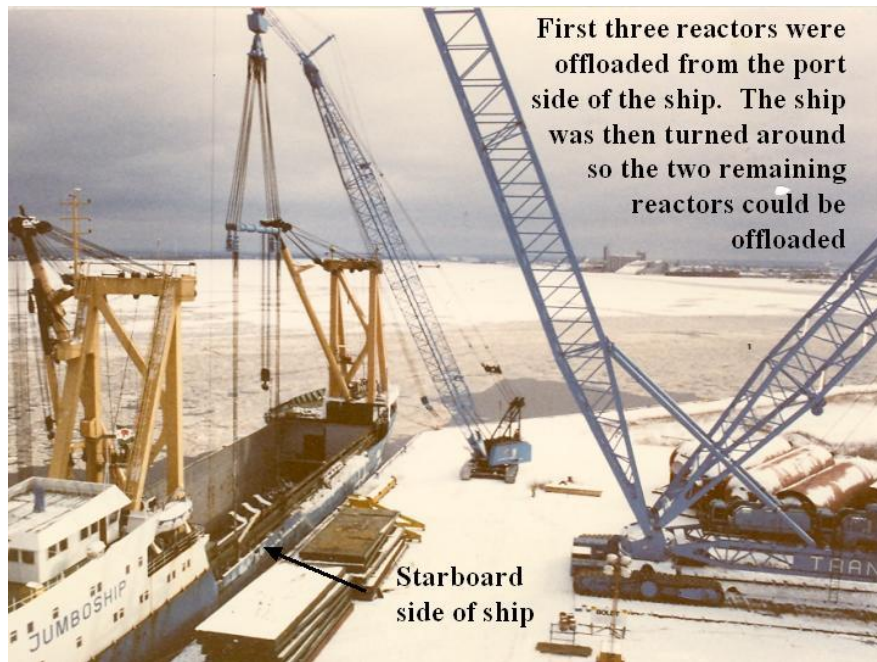

The fifth photo shows a special spreader bar clamped to four 2.5" dia. slings for pulling them under the reactor and on up to hooking them to the 85 ton shackles on the main spreader bar.

Special hook up spreader bars made the 16 hook ups on each end safer & faster

On the average, one Engineering Man-hour in home office spent on safety and efficiency will save one Crew Man-hour in the field = \$1,000 to \$2,000, depending on crew size and equipment involved

In this case, the two bars saved \$50,000

Cost of two bars: \$1,800



The next photo shows the eyes of the slings laying over for easy connecting to the shackles.

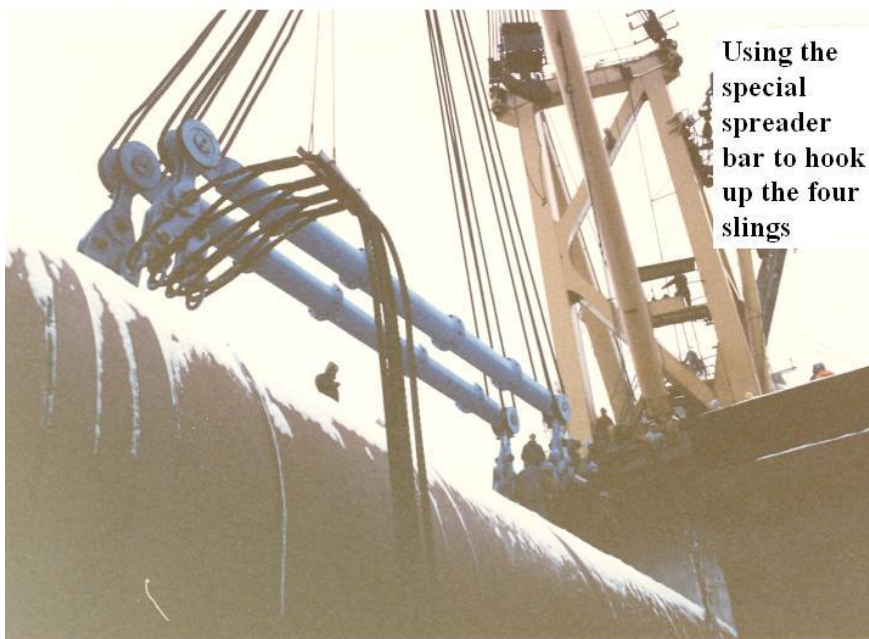

Using the special spreader bar to hook up the four slings

The seventh photo shows the fourth reactor being walked back away from the ship. Note that once the special spreader bars were clamped to the slings, they were left that way until the job was finished.

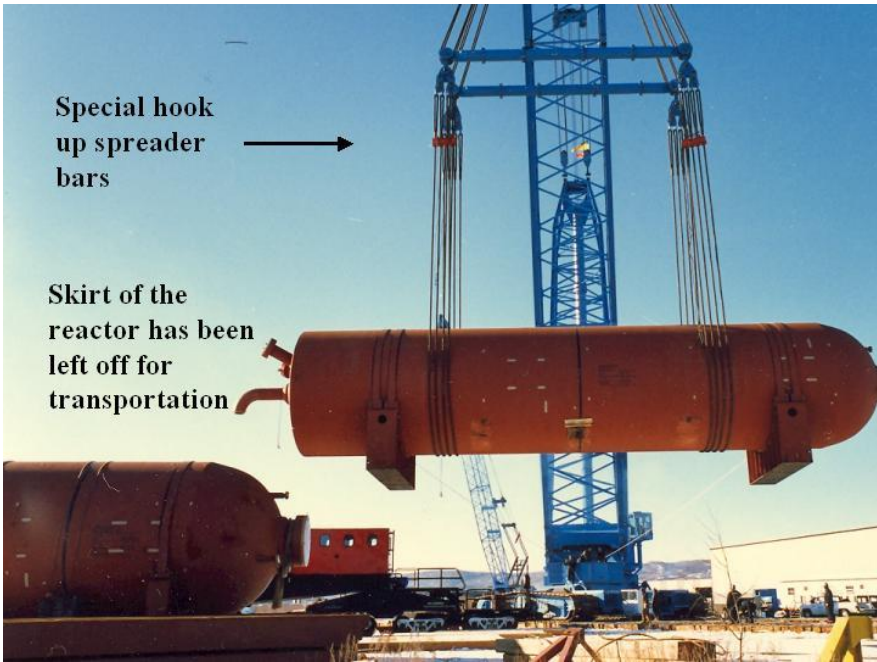

The eighth photo shows four of the reactors staged and the last one placed on the tension members.



The last photo shows the details of the rigging hook up. In the next section, this rigging hook up will be compared to the one used at Regina for offloading the reactors from the Schnabel car.

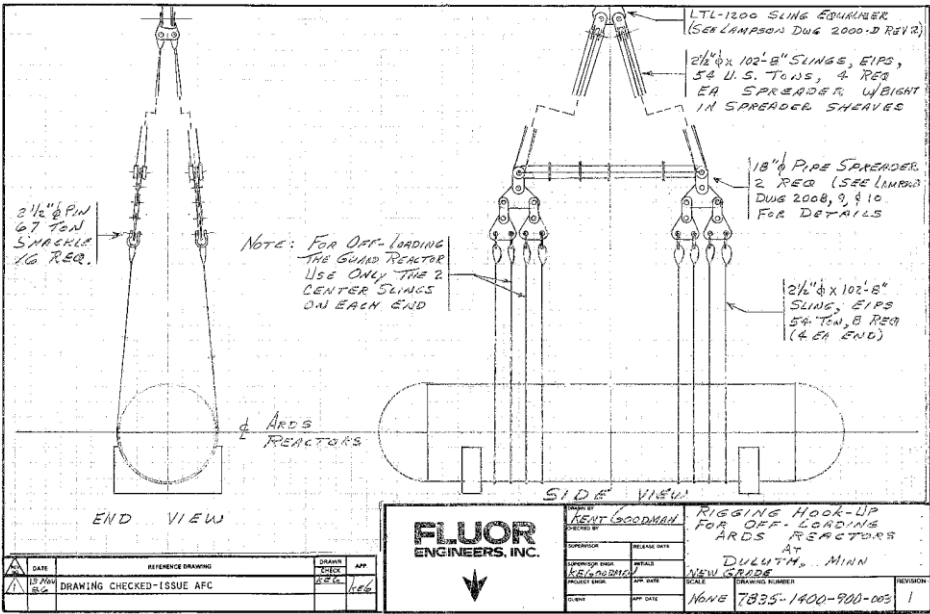

3. A Temporary Work Platform At Regina:

The five reactors were then transported to the jobsite at Regina, Saskatchewan, Canada. The first photo shows a 790-ton reactor being offloaded from the Schnabel car using two 14" dia, Std. wall, x 28' long longitudinal spreader bars. Note the simplicity of the design compared to the spreader bars that were used in Duluth. The eight 3.5" dia. slings were connected under the reactors with four 120-ton shackles. We could have purchased two complete sets of bars and slings for the rental we paid for the one set in Duluth.



The next photo shows the temporary work platform that we designed for 200 psf so the boilermakers could stage themselves and all of their tools including a power pack and hydraulic wrench for removing the four-inch dia. nuts holding the flange lug on. The temporary work platform was held in place by bolting it to the brackets for the permanent platform.

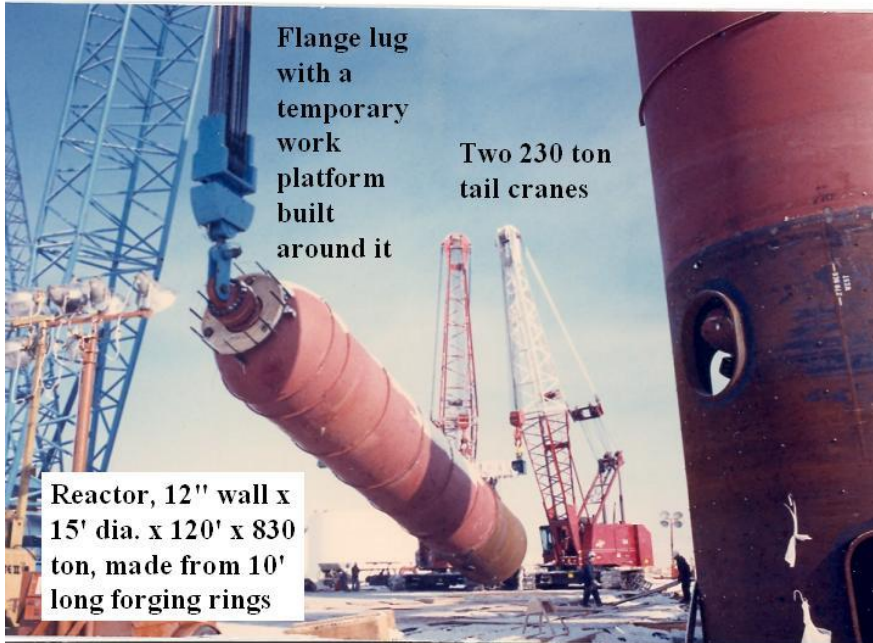

The last photo shows the temporary platform in the upright position on an 830-ton reactor (790 ton reactor plus 40 ton skirt). It was switched to two more reactors for a total of five uses. Again making the operation more efficient and safer.

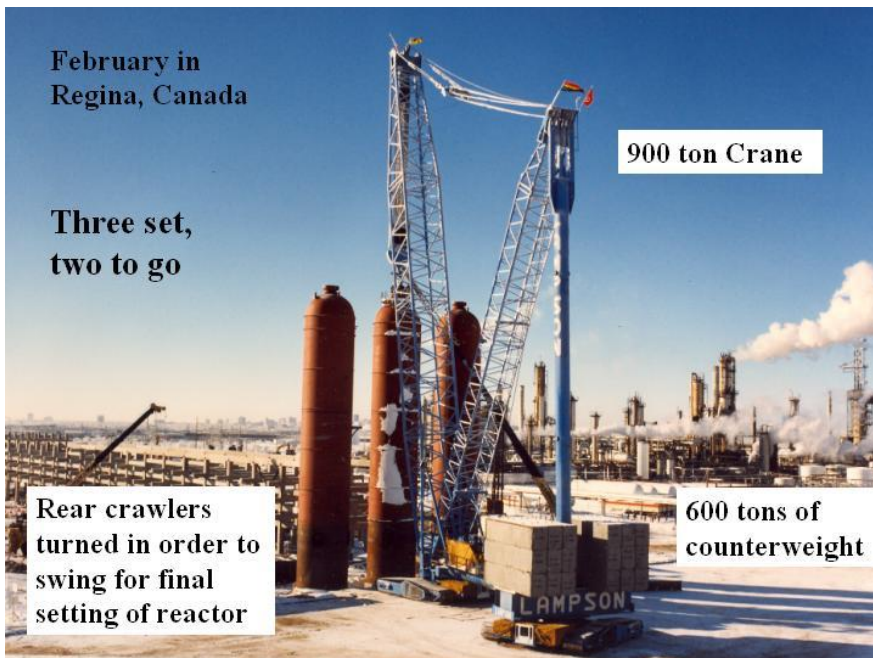

4. Side Hitch Plate:

Many years ago, the Fluor rigging department developed a method for erecting vessels that didn't have lifting lugs attached. This included lifting the top off of tall vertical vessels that had become corroded so bad that lifting lugs could not be welded to them. This method was called the double choke method. The first photo shows a drawing on how to lift a vessel by wrapping doubled slings around it. As you can imagine, this was a very labor-intensive operation and the slings didn't always stay where they were supposed to.

FLUOR RIGGING ENGINEERING MANUAL	CHOKER & TWO CRANES	NUMBER 4.6.8
		PAGE 3
		DATE 2/27/76

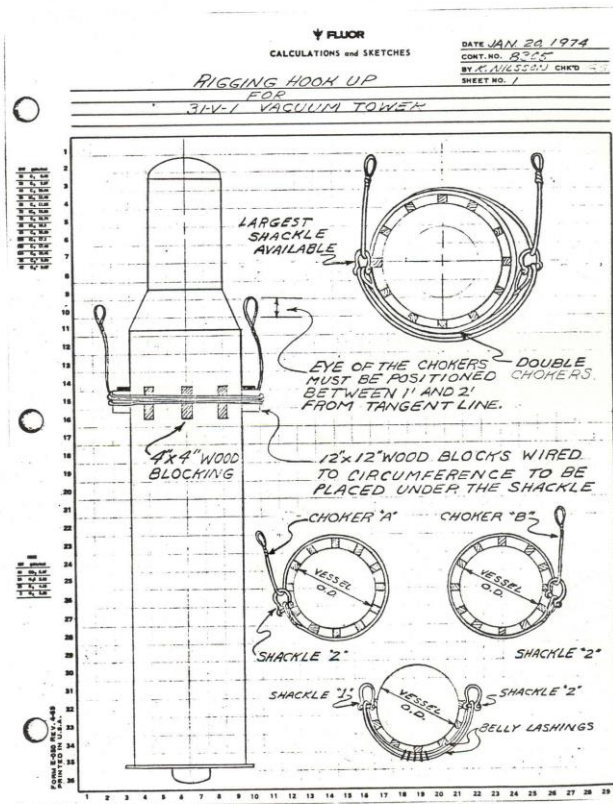

The next photo shows a lift in China (made by another company) where the slings have slipped up almost off the wood lagging during the lift. You can see how hard it is to keep the lift shackles level with one another using this method. But if they are not keep level, then the tension will not be the same in each lift sling.



In 1990 when I was with Jake's Crane And Rigging, a Fluor Rigging Engineer named Bob Poirier called me and asked if Jake's would come to Mt. Vernon, Indiana and bid on removing a tall vertical vessel and replacing it with a new one. I told him that we couldn't compete with the rigging companies in that area so it would be useless for us to even try. Now, I had worked with Bob before at Fluor and knew he was very honest and honorable. So when he told me that he felt we had a good chance of getting the work but we had to come to Mt. Vernon for the job walk in order to be a bidder, I decided to go. He had checked and a round trip ticket was \$1,000. That is all he would tell me, the same as he had told everyone else.

During the job walk, I noticed that this job was tailored for an American 9310 Skyhorse as the vertical vessel weighed a little over 100 tons and was located back next to a pipe rack with a tall structure on both sides. It would have taken a very large truck crane to lift the vessel out over the structures. But, the Skyhorse had the capacity to reach in, pick the vessel off the foundation, walk back, swing it around and down end it. Bob later told me that he had checked and found that there weren't any Am 9310 sky horses available in the area for this lift. The other thing that I found out was the bid documents stated that lifting lugs could not be welded to the vessel due to corrosion. Each bidder was asked to propose a method to lift the vessel and explain it in detail. This is why Bob wanted us to bid on removing this vessel, because he knew we would propose using the double choke method.

Back in Las Vegas, Bill Cunningham and Scott Kallson started putting together a bid while I started making drawings showing how we intended to remove the vessel and lay it down. We submitted our bid, which included quite a bit of contingency for moving a large crane that far and were surprised when we won the contract. Bob later told us that we were the successful bidder for two reason, nobody else had a Am 9310 Skyhorse available and for proposing our double choke method. Our bid was for \$480,000 to move the crane to Mt. Vernon, spend 7 days at site and moving it back to Las Vegas. This included four days for assembly-disassembly and three for rigging. We made some very good money.



As soon as we had the Skyhorse assembled at Mt. Vernon, we removed the large piping from the vessel and then put our rigging on the hook. It was made up of a spreader bar and two 2.75" dia. short slings. Longer 2.75" slings were connected to the short slings. We chose to double choke the vessel just above a 180-degree platform. We hung 6' long 4" x 4" dunnage from the top nozzle with rope & eye bolts to provide friction between the insulation and the slings. With four men working off the platform and three working out of a basket suspended from a crane, it took us six hours to rig it up. The above photo shows the Skyhorse hooked up to the vessel. As a safety measure when using the double choke method, I always connected boot strap slings with a shackle at the bight of the double choke slings and hooked them down to nozzles or lugs at the base of the vessel. This time was no different as we shackled the bootstraps down to lugs that we had welded to the basering. The bootstraps were not intended to carry a lot of load, just to keep the bight of the double choke slings from moving up and thus keeping the shackles level.

The next photo shows how the bootstrap slings were hooked.

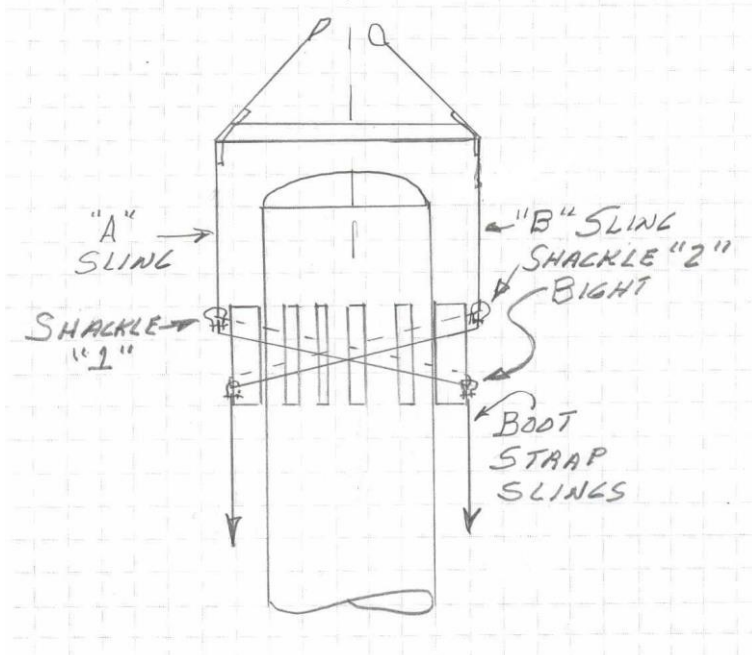

As soon as we were rigged up, we lifted the old vessel, walked it back until we could swing the Skyhorse 90° and down ended it using an Am 8460 truck crane for tailing. We then removed the long 2.75" slings, hooked up to the new vessel that had lifting lugs on it and set it.

As I was flying back to Las Vegas, I said to myself, "there has to be a better way than using the double choke method", as it was so labor intensive and dangerous. So, I started making some sketches and by the time we landed, I had a pretty good idea for a method that I felt would replace the double choke method. Later, I finished the design and then called it the Side Hitch Plate Method. The next photo shows the details of this method.

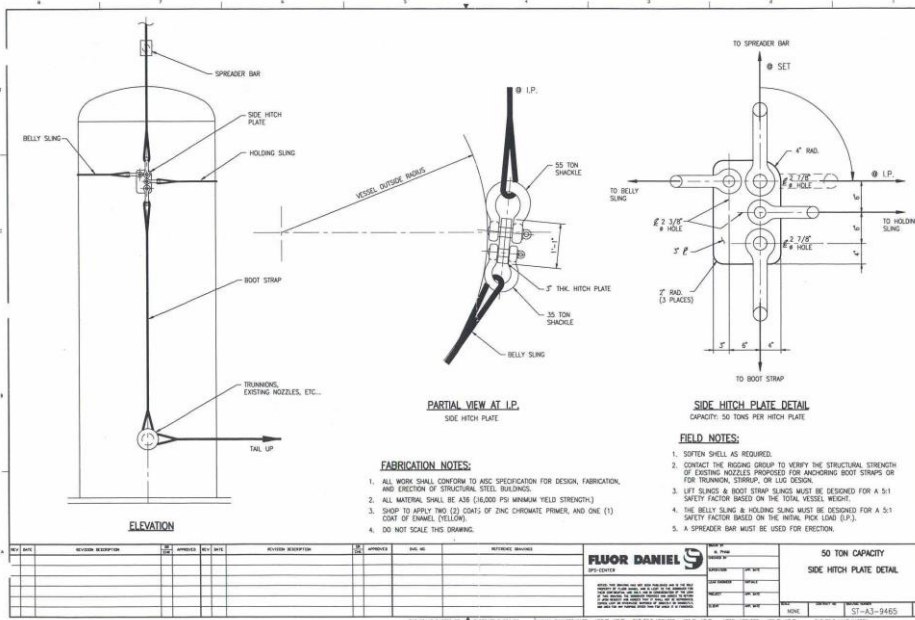

To use it, all you have to do is to hang all of the rigging on the hook, swing the rigging into place around the vessel, have someone hook up the holding sling from a platform or out of a basket (sort of like a woman putting on a bra), hook up the boot strap slings to lugs at the base and then lift the vessel. We have used this method many times and it works real well. Shurtleff and Andrews used it to remove the top section of several vessels at the Chevron refinery in Salt Lake City, but Brad Shurtleff could not find his photos. So, I apologize for the condition of the next four photos. The first photo shows the top section of a vessel being lifted off the bottom section by the side hitch plates.

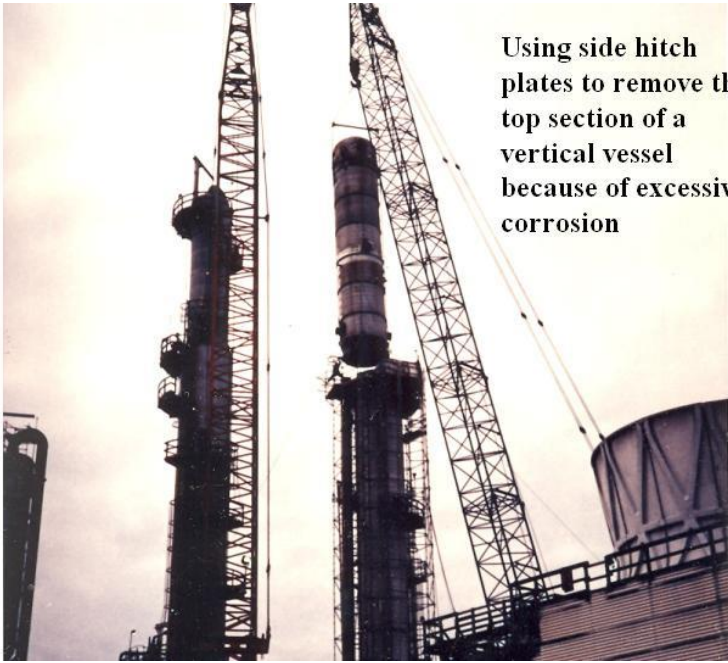

Using side hitch plates to remove the top section of a vertical vessel because of excessive corrosion

The next photo shows the top section down on the ground.

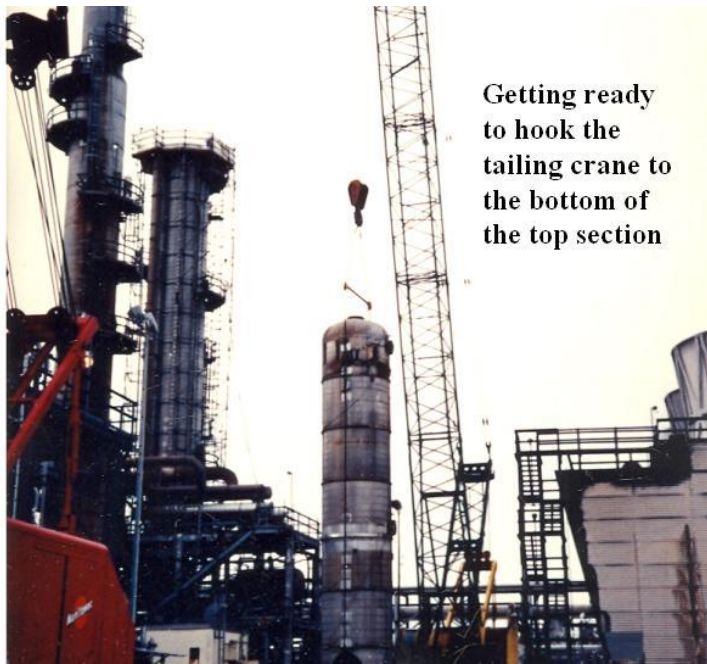

The next photo shows the tail crane being hooked up.

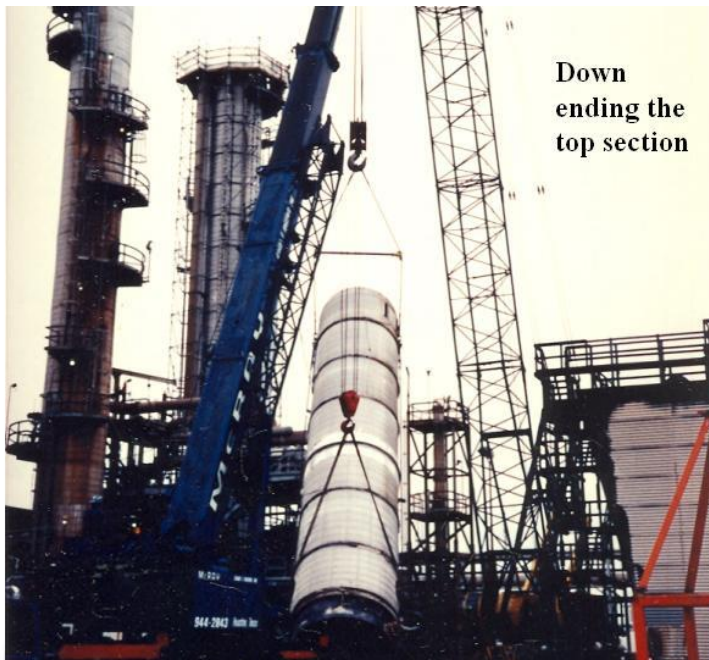

The last one shows the top section horizontal. It is not real clear, but you can see the various components of the side hitch plates in the last photo.

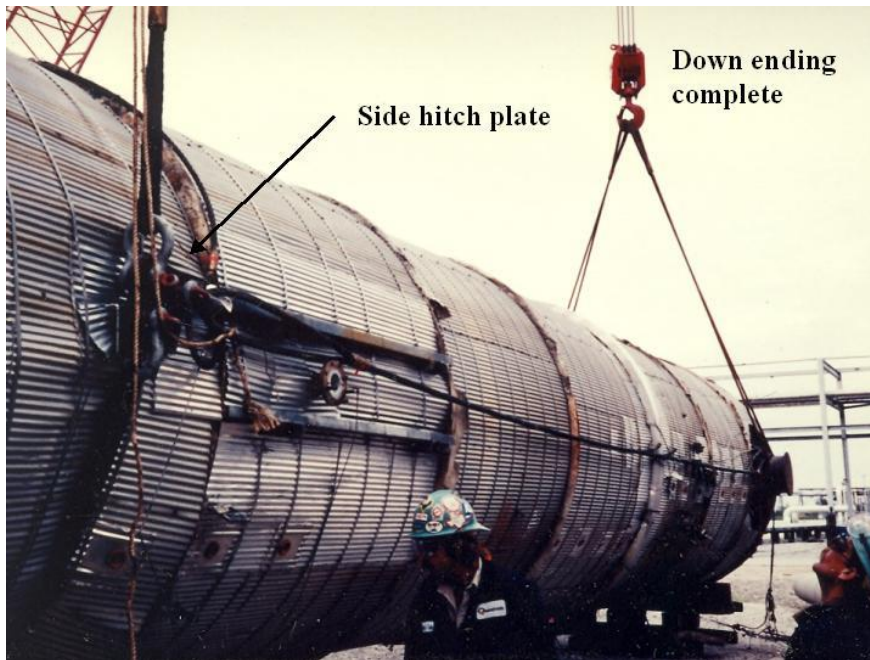

I believe that if we had used the side hitch plates to lift the vessel at Mt. Vernon, that we could have hooked it up in less than an hour compared to the six hours for the double choke method and done it much safer.

DESIGN AND EXECUTION OF ENGINEERED LIFTS:

When Fluor received a new contract to Engineer, Procure and Construct (EPC) an oil refinery, the first thing that the rigging engineering department did was obtain a plant equipment list. They then made out a “rigging progress report” and listed on it the equipment that they felt should be classified as “Engineered Lifts”. The report and the equipment list were sent to the field Construction Manager for his review. The Construction Manager knew that all other lifts on the equipment list would be non-engineered lifts and would be the field’s responsibility. He either approved the report or made changes, ie, he might add a lift from the non-engineered list because it was up high in a structure, etc. As soon as the Construction Manager approved the rigging progress report, it became the rigging engineering department’s scope of work.

Once the rigging engineering department designed a lift and completed the drawing(s), they were issued as Rev 1 to the field as Approved For Construction (AFC). It was the field’s responsibility to review the drawings. If they did not approve the drawings for any reason, they sent it back to the rigging engineering department marked up with their proposed changes. These changes might be that they had installed some plant equipment that the rigging department didn’t know about, or they wanted to set the crane in a different location, etc. The rigging engineering department would review the proposed changes and if they agreed, they revised the drawing and sent it back to the field marked Rev 2.

Now it was the field's responsibility to make the lift using the rigging drawing with the latest revision. If the field made the lift according to the drawing and something happened, then it was the rigging engineering departments fault. If on the other hand, the field deviated from the rigging drawing in any way and there was a problem or accident, then the responsibility was the fields. This worked very well, with both the rigging engineering department and the field knowing exactly what their responsibilities were. It also fostered a bond of trust between them.

I would like to talk about four occasions when the field did not follow the rigging drawings and each one ended with serious consequences. In talking about the one near miss and the three accidents, I am not trying to point out that the field personnel are a bunch of dummies, but that sometimes decisions are made for different reasons and sometime people have different agendas. These examples are good lessons learned.

1. Reactor Lift:

Fluor had a project in Iran that had eight American 9310 Guy Derrick lifts on it. Dennis Jantz and I made the crane studies in Irvine and issued the rigging drawings to the field for all of the engineered lifts. Then we were both sent to the site as rigging engineers working under a very experienced rigging superintendent named Lennie. This was our first field assignment with Fluor.

One of the lifts was setting three 275-ton reactors from one set up. The first photo shows a reactor being upended and the three foundations directly in front of the Guy Derrick.



In getting ready for this lift, the division of labor was Dennis and I was to place the deadmen, layout and tension the guy lines. Lennie and his two Expat crane operators were to construct the lift pad, lay the crane mats on it and then position and block the crane per the drawing. There was a note in the set up section of the drawing that said "Position the crane at the planned radius, set the travel locks and back up against them". The second photo shows a sketch of the travel locks. Some old timers call travel locks "digging dogs" because cranes were used a lot for dragline work and the locks kept the cranes from being pulled into the hole they were excavating. AH&D were very adamant that their travel locks were not

digging dogs, hence the cartoon at the bottom of the sketch. My thanks to Ron Kohner for providing this sketch.

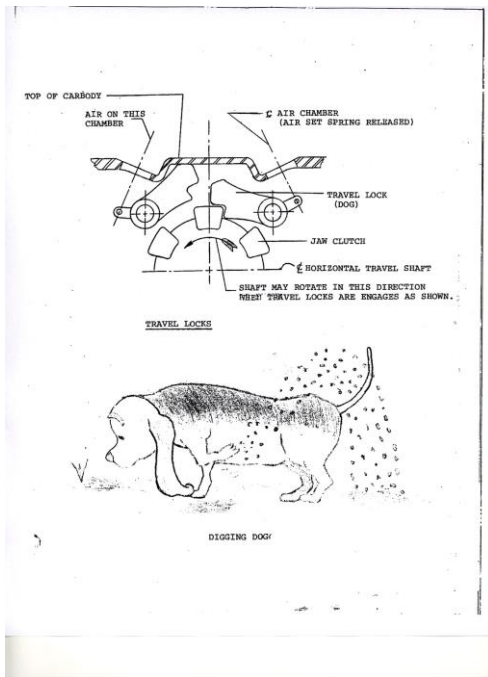

Another note said “Next install wooden chocks behind both tracks and use lag bolts to secure 1/2” x 6” x 6” angle rails to the crane mats behind the chocks and against the tracks on the off side from the load”.

The third photo shows chocks and rails from another lift similar to the ones that should have been installed on this lift.



In going from one deadman to another, I took a short cut by the lift pad and noticed that the chocks and rails were not installed. I told Lennie I knew where they were stored in the lay down yard if he couldn't find them. He looked up at the crane, on up to the mast and the guy lines and said, “this rig is so heavy, it

isn't going anywhere". I told him that I had calculated the sliding force from the boom and compared it to the resisting force between the tracks and mats and that we only had about a 1.25 safety factor. I also told him that AH&D recommended that the chocks and rails be used. Later that day, I went thru the lift pad area and the crane was still not blocked. Again I talked to Lennie but he was still firm in his belief that all was well. In the afternoon of the next day before we were to lift, I again went to Lennie and strongly recommended that we use the blocking. Again he said he didn't believe it was necessary. I then went to the office and talked to both the Construction Manager and the General Superintendent and told them of my concern. We talked about it for a while and then they basically said that Lennie had many years of experience, that he was in charge, that they trusted him and inferred that I was just a lowly Rigging Engineer with only one year of experience. I told them I was glad to have the chance to go on record in talking to them and voicing my concern in case any thing happened. That statement didn't set to well with them and I got long stares as I left their office. I decided that the next time I was put in this position, I would ask the CM for a letter directing me to go ahead and make the lift even though it wasn't being made according to the rigging drawings and that the CM would assume responsibility if any thing went wrong. Later, as I was training young rigging engineers, I instructed them to do the same.

The next morning we started at daylight and upended the first reactor.



Removing the tail beam.



It was then to be swung to the right and set on the far foundation. All went well until the reactor was pretty well over the middle foundation with the base plate about 18” above the anchor bolts. All of a sudden the crane slid backwards about 4’ and then stopped with the base plate of the reactor about 1.5” above the anchor bolts. I feel that the reason it stopped sliding was this. The mast foot pins are located about 4’ in front of the center of rotation but when the mast is “plumb” it is actually leaned backward until the mast tip is over the center of rotation. As the crane was sliding backwards, the mast foot pins were moving to where the center of rotation was, which was making the mast truly vertical and pushing up harder against the guy wires. This increased the sliding friction between the tracks and the crane mats to a point where sliding stopped. Lennie immediately had a rigging crew go to the rigging yard and bring back a large reel of 1 1/8” hoist line. They started wrapping it around one side frame, then around the center foundation, around the other side frame and back again until they had four wraps. He had another crew bring in the chocks and rails from the lay down yard and install the **chocks** behind the tracks. So much for locking the barn door after the horse is out.

While they were doing this, the chief engineer came to me and told me that he felt that the crane had started rolling and then slid the rest of the way. He had a transit set up perpendicular to the car body and in monitoring the tip of the mast for plumbness, his reference point at grade was the machine mark in the center of the drive sprocket on the end of the travel shaft located in the center of the car body. But as the machine mark was occasionally in a shadow, he had his Rodman put a mark up on the edge of the track. He pointed out that the mark on the edge of the track was about 6” back from the center of the sprocket. Lennie asked the expat crane operator, who was operating the crane when it was being set up, if he had backed the crane up against the travel lock. He replied no, he didn’t because no one had instructed him to. So much for following the notes on the drawing. If the crane had been backed up against the travel

locks, it probably would not have slid at all. See the next photo for the location of the machine mark on the drive sprocket.

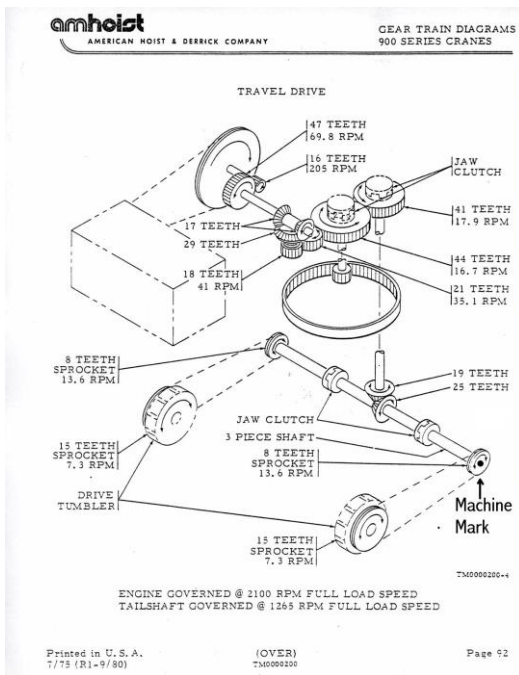

As Lennie and the riggers were lassoing and securing the crane, we positioned a transit behind the crane and checked the mast for deflection side ways. The maximum allowable side deflection was 6". The deflection was 12" so we tightened up on an opposing guy line and pulled the mast back inside of tolerance. We then raised the reactor until it was clearing the anchor bolts by a good foot, swung it about 2 degrees, moved the transit and checked the side deflection and again pulled the mast back in tolerance. We continued to do this until we were over the far foundation. We then lowered the reactor down over the anchor bolts. See the last photo that shows the reactor being lowered down over the anchor bolts on the far foundation.



As we were doing the above operation, I noticed that Lennie had his riggers laying out the rails on the backside of the tracks from the load at initial pick. From this I knew that he intended to upend and set the other two reactors from this location. It was about noon by this time and Lennie told the crew to go to lunch. I had to go to another area to check on one of my crews that were setting a small vessel but I stopped Lennie and told him that if we lifted the other two reactors from this location that we would buckle the mast. I explained that the mast foot pins were now over the original center of rotation as was the tip of the mast. When we swung the crane 90 degrees to upend a reactor then the mast would be deflected sideways by 4'. I asked one of the surveyors to give me a pencil and I demonstrated that the mast was free to rotate over the mast foot pins by holding the pencil at the bottom and moving it in that plane back and forth. But as I held the pencil firm at the bottom, I bent it sideways until it broke in two pieces. I then told Lennie to let me know what he decided and I got into my pickup and left.

My lift was about finished when I got there so I sat down in my office to eat lunch. I had no more than got started when Lennie called me on the radio and asked if I was about ready to return to the Guy Derrick. He said, "We need to talk". When I drove up, everybody was sitting in the shade of a pipe rack. As I got out of my pickup, Lennie stood up and walked over to me, turned to face the crew, put his arm around my shoulders and said "Okay boss, tell us what to do so we can erect another reactor". From that day on, Lennie and I were friends and we worked on four more jobs together. In fact, in the photo of the crude column lift, Lennie was operating the guy derrick in the background.

I chose this example to point out that as our cranes get bigger and more complex, it isn't always intuitive what is going on inside them. For this reason, we have to go by the manufactures recommendations and follow the procedures on the rigging drawings. Lennie Newman was a brilliant Rigging Superintendent but this was his first guy derrick lift and he didn't have a feel for it yet.

2. Erecting a 300' Flare stack:

Two American 11320 guy derricks were used to make all of the heavy lifts on an oil refinery that Fluor constructed in Venezuela. This story starts as all of the heavy lifts had been completed except the

erection of a 300' freestanding flare stack. The rigging engineering department initially completed a crane study for this lift and found that a 320' boom and a 60' x 75 ton jib would be required. The plan was to walk the last guy derrick being used out of the unit over to the boom-changing yard. There the 250' boom was to be laid on the ground and extended to 320' plus adding the 60' jib. As this combination of boom was not self erectable by the guy derrick, we proposed burying two deadmen in back of the guy derrick, running a single guy line from the 270' mast down to each deadman, snugging up on the guy lines and booming the boom up into the air. The first photo shows our proposed method, which we sent to the field as Rev 1 about 6 weeks before lift date.

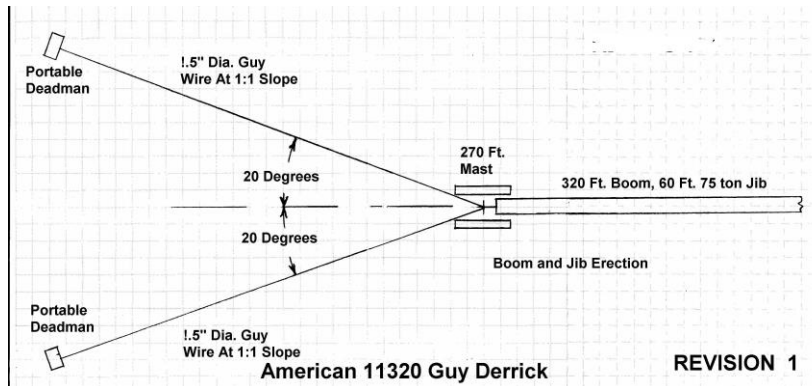

The next photo shows the standard portable deadmen that Fluor used.



About a week later, the field called and asked if two Manitowoc 4100 lift cranes could be used as deadmen. We checked the sliding resistance between the soil and the tracks, the integrity of the lugs on the carboy's, revised the drawing and sent it to the field as Rev 2.

About a week later, the field called and said the Manitowoc 4100's would not be available for deadmen and wanted to know if they could assist the boom up with the second Am 11320 lift crane. We went back to the drawing board and found out that it would require a 310' boom in the Am 11320 lift crane to assist the guy derrick boom up to a boom tip height of 245'. As this 310' length was not self-erectable, we

found that an Am 9310 lift crane with 280' of boom would be required to assist the 310' of Am 11320 boom up. A truck crane with a basket was also needed to cut the rigging loose for the Am 9310 lift crane and for the Am 11320 lift crane. The next photo shows the summary of the cranes involved with this scheme. The drawing was marked Rev 3 and was sent to the field.

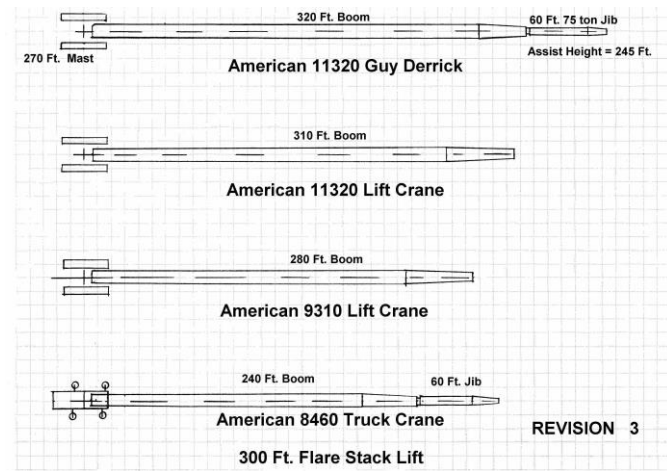

We didn't hear again from the field until the Construction Manager called us and said there had been an accident in erecting the boom on the guy derrick and that it was a total lose. He said the mast almost went over backwards but the boom tip section had prevented it. He wanted to know what went wrong, insinuating that we were at fault, and wanted an immediate review of the lift by the rigging engineering department. We were at a lose and asked him to send us the site accident investigation report and all of the photos that he could round up that were taken before the boom erection started, during and after the accident. We were on pins and needles waiting for the above information as our Department Manager kept looking at us side ways. Meanwhile, the field had ordered a new boom and jib at cost of \$500,000. The cost for flying it in was another \$500,000.

When we received the accident report and the photos, we spread them out on a table in our conference room. The accident report said that everything went according to the plan up to where the boom tip was assisted up to an elevation of 265' and the Am 11320 was unhooked from the guy derrick boom. Then as the crane operator started to boom up, the boom exploded. That was it, so it must have been the rigging engineering departments fault, right? The first question in our minds was why did the field assist the boom tip up to 265' instead of the 245' listed on the drawing?

A lot of the photos were not too helpful, but one set showed three panoramic side views of the crane and boom.

The first set included four photos, which were taken before the boom erection started. As we were very familiar with the American boom sections, it didn't take us long to discover that the boom was actually 340' long with a 60' jib. We then calculated that the assist height for this boom would be 295'. We also noticed that there was a Caterpillar D8 being used as a tie off cat. Slings were running down from the top of the A-frame to the drawbar on the cat. The slings looked tight. Have you guys seen a tie off cat being used? The next photo shows an example of a tie off counterweight.



If it is felt that a tie off cat needs to be used, the next photo shows how to use it correctly. First, disregard the guy wire at the top of the mast as this was the best photo that I could find for this illustration. Next, the tie off slings should never be tight, unless the crane or guy derrick is starting to tip over.

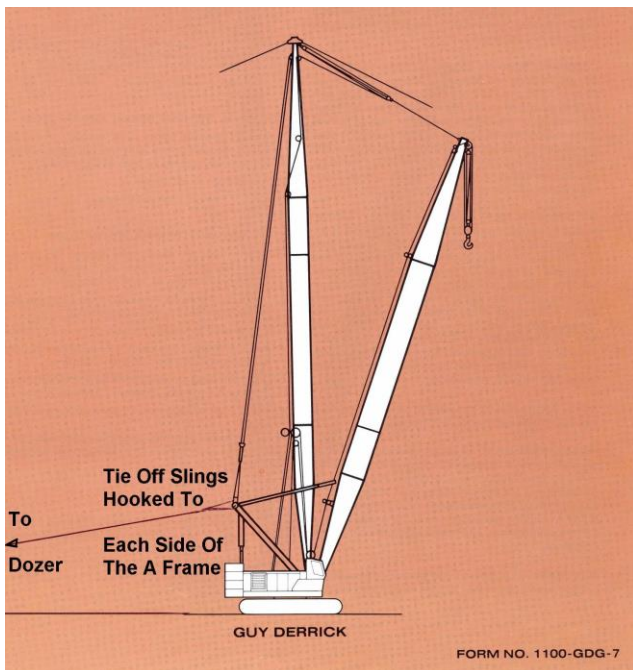

The second set of four panoramic photos showed the Am 11320 lift crane being unhooked from the guy derrick boom point. One of them also showed both load blocks being supported by the hoist lines, but the hooks were still laying on the ground. A note on the drawing said the load blocks should not be supported by the hoist lines until the boom was at a 60-degree angle. At this point the boom angle was approximately 50 degrees.

The third set of photos were taken just before the accident and showed both load blocks just clearing the ground and the tie off slings tight.

We called the field and asked them 1) why a tie-off cat was used, 2) why they had installed 340' of boom instead of the 320' per the drawing, 3) why they raised the boom tip to 265' and 4) why the load blocks were being carried by the hoist lines instead of laying of the ground. They replied:

1. The tie-off cat was just used as a safety precaution.
This was not true because to use a tie-off cat correctly, the slings must be left slightly loose so anyone can tell by looking at them if they are carrying any load. Then if they tighten up, you will know that they are preventing the crane from going over. In this case, if the slings had started out being slightly loose, but then tightened up when the assist crane was cut loose, the field would have known that the crane was trying to tip over and that they should assist the boom tip up higher.
2. The field said they decided to complete the erection of the 300' flare stack and then lift the center pipe over the top and lower it down into place. This would require a 340' boom.
3. They figured that adding 20' of boom would require assisting the boom tip up another 20' higher to a tip height of 265'. We told them that it wasn't linear, but exponentially.
4. They said nobody noticed the note on the drawing about the load blocks.

We wrote up our report, changed the drawing to Rev 4 which showed the guy derrick with 340' boom and the assist height of 295' and sent it to the field to show them that this was the drawing they should have been using when they tried to erect the guy derrick boom. The next photo shows the Rev 4 drawing.

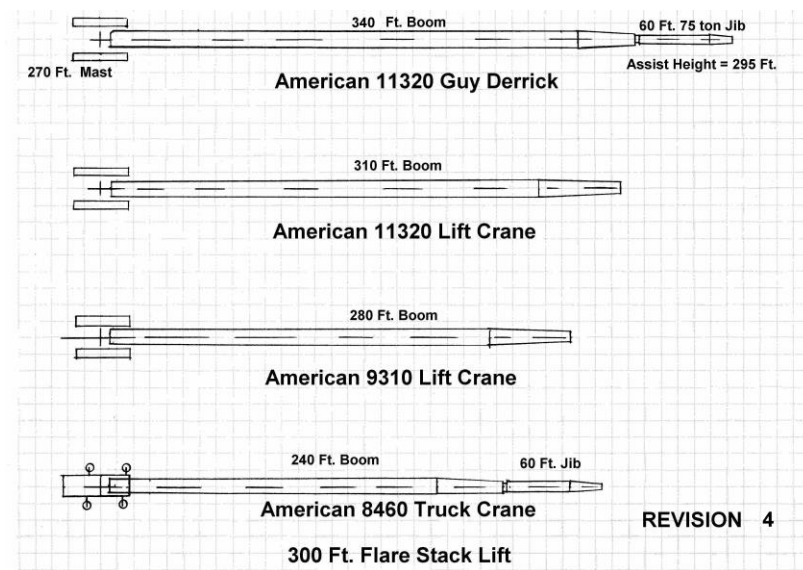

We never received any comments on it from the Construction Manager. At least our Department Manager stopped looking side ways at us. We also asked them if they wanted to go back to the original plan for erecting the boom using deadmen and guy lines and they said **yes**.

So, we dusted off the original drawing marked Rev 1, changed the boom length to 340', changed it to Rev 5 and sent it to the field. The last photo shows Rev 5.

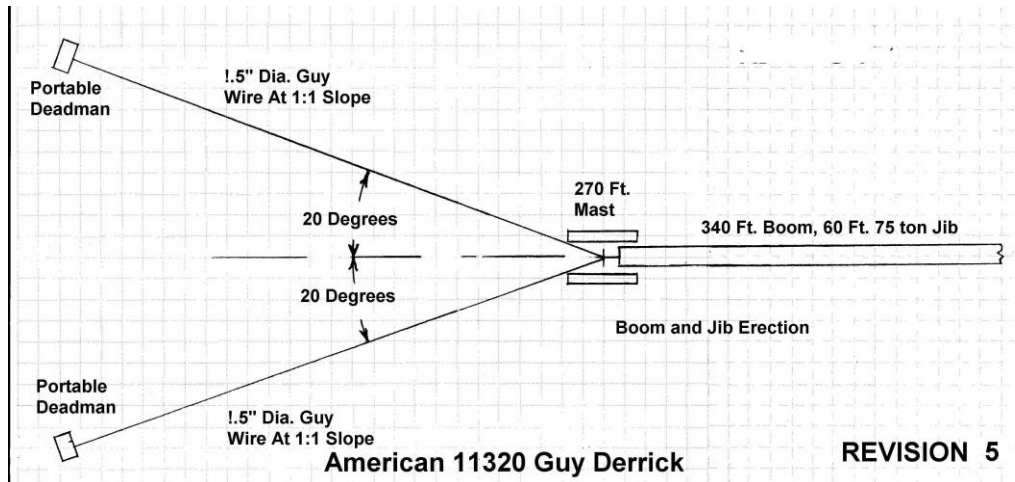

While the field was waiting for the new boom and jib to arrive, technicians from AH&D lowered the mast on the guy derrick and performed non-destructive testing on all of the mast sections. They found that most of the swage fittings on the boom & mast pendants had been stretched, as the pins would not even turn in them. At the same time, the field also buried the two deadmen and stretched out the tensioning systems. As soon as the new boom and jib was installed, the guys were tensioned and the guy derrick self erected the boom. The tensioning system was disconnected and left in place on the ground. When the flare stack was completed, the field walked the guy derrick back to the boom yard, hooked up the guy wires/tensioning system and lowered the boom to the ground.

Most of the time, simpler is easier, faster and safer.

I chose this example to show how sometimes a decision that is not well thought out can snowball into other decisions being made that makes the situation worse. I do not think that the field rigging department made the above decisions.

3. Guy Derrick Erection In South Africa:

We designed a guy derrick lift for a vessel in Sasolberg, S.A. The lift had six guy wires with one of them running straight back from the guy derrick. This doubled guy wire went over a high conveyor structure and one of the set up notes had an asterisk that said “Hold this guy wire up with a crane hook until it is tight enough to clear the conveyor structure”. The field didn’t notice or didn’t pay any attention to this note. When the field started tensioning up the guy wires, the crew on the one over the conveyor got a head of the other crews. They were tensioning up the live side of the doubled guy wire and didn’t seem to be taking any slack out of the dead side. What they didn’t notice was that a socket on the dead side was caught on the conveyor structure and they were slowly pulling the mast over backwards. They continued to pull on the live side until the mast and boom both fell over backwards.

As a lesson learned, we started setting the boom tip over the foundation for guy wire erection and tensioning. We designed a lug that fit over two anchor bolts. We had the operator lower the load block until it could be hook to a sling connected to the lug. The crane operator was responsible for monitoring the sling to make sure it had some slack in it but didn’t get tight.

I chose this example because it shows a number of things that were not done right, ie, it should have been pointed out to the crew how important it was to hold up the doubled guy line, someone should have been monitoring the mast time movement, someone should have been supervising the tensioning of all of the

guy lines and not let one crew get ahead of the others, etc. In fact it seemed like no one was supervising the setup.

4. Deep South Crane Accident At LyondellBasell:

As you probably recall, Deep South Crane and Rigging was setting up one of their heavy lift cranes, a TC-36000, when they had an accident. They had erected the mast and boom and were in the process of hooking up the mast pendants to the auxiliary counterweight (Demag calls this counterweight the Super Lift) when the mast and boom came over backwards. See the next photo that shows the mast pendants hooked to the auxiliary counterweight on a Deep South Versa Crane. I don't think it is a TC-36000 and am using the photo just for reference.



The boom and mast fell on another crane and a personnel structure killing four workmen, two of whom were operating engineers. I read the accident report where it stated that the minimum boom radius was shown on the setup plans. It was not clear why the boom was set at a shorter radius. Here is a case that could also have benefited from hooking the load block to a tie off lug with the operator monitoring it.

A good question to ask would be how could these experienced operators and riggers let such a thing happen when management and everyone in the refinery was expecting them to follow good rigging practices and do everything they could to do no harm? But, it is sobering to think that Heavy Lift Contractors do this sort of operation on a routine basis. So I recommend that you develop good set up procedures and follow them to the letter.



NON-ENGINEERED LIFTS:

As stated above, 95 % of all crane accidents are from non-engineered lifts. So there is a lot of room for improvement in this classification of lifts.

In 1995, I got a call from the Construction Manager on a Fluor project in Thailand. The heavy lifts were completed and the project was about 75 % completed with several units on line. The reason for his call was to tell me about an accident that had just occurred where a 50 Te hydraulic crane was installing a luffing jib on a 400-ton truck crane. The 50 Te crane turned over next to a live unit and the boom missed hitting a live hydrogen line in a pipe rack by about 1'. The Photo below shows the accident and it will be discussed in greater detail later.

50 Te Crane turned over on 400 Te crane

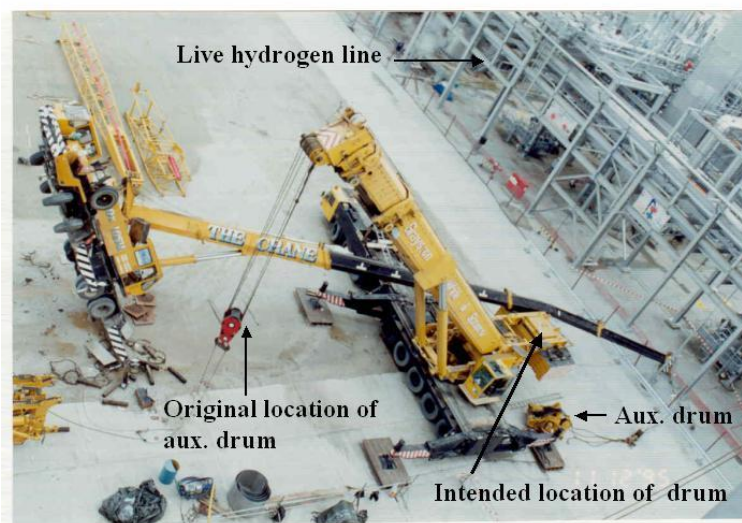

The client was so disturbed that he shut down all Fluor crane lifts until he could be convinced that the remainder of the job would be completed with zero crane accidents.

Up to this point in time, Fluor did not have a Crane and Rigging Procedure for the field. When a project started, the Field Construction Manager was issued a large thick manual called "Field Rigging Manual". It contained a lot of good information about slings, rope, etc, but was very general concerning cranes. Other than this he was on his own. So you can see why there were so many non-engineered crane accidents.

It had been bothering me for some time that Fluor did not have a Crane and Rigging Procedure for the field and that we were having so many accidents with our non-engineered lifts, but having our plate full with the engineered lifts, I shoved it to the back of my mind. But, as I was on an airplane headed to Thailand, I decided that this might be a good time to remedy that. I decided that if we could write a good crane and rigging procedure for this Thailand project that would be acceptable to the Client and the Construction Manager and would actually reduce the crane accidents to zero, then we could later adapt it in to a companywide crane and rigging procedure.

Lift pad settlement, the crane tipping over, or a combination of the two causes most crane accidents. I thought about this and decided that the one single thing that could be done that would have the most impact in reducing these accidents was to restrict the non-engineered lifts to 75 % of lifting capacity chart. I reasoned that this would not penalize the field to much as they could always upgrade a lift to an engineered lift without bringing in a larger crane. An engineered lift can be made up to 100 % of chart.

To help prevent lift pad settlement, I reasoned that blocking or load spreaders should be used under each outrigger float regardless if the crane is being set up on soil or on concrete. The blocking or load spreaders under the outriggers should be sized to provide at least a minimum of 400 percent more load bearing area than the outrigger float provides and to resist the resulting bending stresses. All crawler cranes should be working on mats.

The next major thing I felt would have a large impact in reducing accidents was to require the use of a lift permit for all lifts over 50 % of capacity. It would be a fill in type so that at the bottom, the user would know if the lift was a go or not. Also, I had checked enough contractors lift plans to know that what they put in their plan/drawing and had it approved by Fluor, was not always what ended up being used in the field. So I included a third signature on the permit for a rigging supervisor to sign off after he had

inspected the set up and the rigging hook up. The next Photo shows the lifting permit.

LIFTING PERMIT FOR CONSTRUCTION SITES				
This form must be filled out by the area supervisor for all "field to rig" lifts and given to the Rigging Foreman for his review a minimum of 24 hours before lift time. Permission for the lift may be denied or delayed if the above time scale is not observed.				
PROJECT/CLIENT		CONTRACT		
AREA		SUBMITTAL DATE		
Date Crane Required	FROM TO	HOURS CRANE IS	FROM TO	HRS HRS
1. Item number and description of the load.				
2. Model of crane to be used _____ boom + jib length _____ + _____ Attach the load capacity chart to this form.				
3. Weight of the load (attach document to show how weight & CG was verified.)				
Te				
4. Weight of the load block, overhaul ball & hoist line:				
Te				
If weights are unknown: Up to 50 Te hydraulic crane, Use 0.7 Te Up to 100 Te hydraulic crane, Use 1.3 Te				
5. Weight of the rigging: (Attach the rigging hook up drawing to this form.)				
Te				
For normal rigging (no spreader bar, etc.) use 0.3 Te.				
6. Effective weight of the jib:				
Te				
7. Other weight:				
Te				
8. Total erection load : (Lines 3 through 7)				
Te				
9. Operating radius (maximum):				
meters				
10. Capacity of the crane at above radius and boom length:				
Te				
11. Working capacity of the crane: (Line 8 divided by line 10, times 100)				
%				
SIGNATURE OF APPLICANT		AREA RIGGING COORDINATOR		DATE
(Name and signature)				
APPROVAL OF THIS LIFT		RIGGING FOREMAN		DATE
(Name and signature)				
CRANE SET UP APPROVAL		RIGGING FOREMAN		DATE
(Name and signature)				
Time crane is released from above lift to return to crane yard.				HRS
THIS APPROVAL PERMIT MUST BE WEATHER PROTECTED AND DISPLAYED ON THE CRANE DURING THE LIFT				

The third major item was to require all cranes that came on site, whether they were Fluor owned cranes or local rentals, be inspected and load tested. The procedure called for a fenced area right inside of the equipment gate where all cranes would be directed as they arrived at site. There they would be inspected for proper crane documentation, leaks, modifications and equipment damage. If any of these were found, the cranes would be sent back to their owners. If the cranes passed the first inspection, they were then given a full functional operational test including a long radius load test using concrete weights. This also gave the field the chance to observe the crane operator to see if he was well coordinated and was experienced in using his crane. The above inspection was repeated monthly. It didn't take long for the local crane rental companies to see that they couldn't send their junkers and leakers to the Fluor jobsite or they would just be sent home. Pretty soon, the Fluor jobsite had the best rental cranes in the area.

After we could see that the Crane and Rigging Procedure was working for the Thailand project, we reworked it, got the Fluor Home Office Safety Department's approval and introduced it to the company world wide. It wasn't long until our non-engineered accidents fell sharply. I don't think they will ever be zero because the company is working in so many foreign countries, many times using less than qualified operators and riggers.

I am sorry to say that not all of the Fluor Construction Managers embraced the procedure with open arms. Some of them spent as much time trying to figure out how to get around the 75 % restriction, the load testing, etc, that it would have been cheaper for them to go by the procedure. After I retired, the procedure was changed to 80 % of chart and in some cases 90 % is allowed. This, even though most clients now require the 75 % of chart when working in their refineries. The third signature has also been removed from the lift permit. O' well, you can't win them all.

Every company should have a Crane & Rigging Procedure for the field for non-engineered lifts and I encourage everyone of you to use it with a positive attitude so that your crane accidents will be Zero.

INSPECTION & LOAD TESTING:

I just want to say a few words about inspection & load testing other than those OSHA requires for crane and rigging gear.

Long Radius Load Test:

I would recommend that you perform a long radius load test each time you set up one of your cranes with lifting capacity of more than say 200 tons. This load test would be primarily to test the assembly of the crane. To perform this long radius test, a known weight would be boomed out to a radius that would load the crane to 100 % of capacity chart for a crane configuration.

Load Testing Greater Than 100 % Of Capacity:

I do not believe in load testing a crane to more than 100 % of the capacity chart. Doing so eats in to the Manufactures design for safety. If a crane is being load tested for a specific load and the load is less than 100 % of the chart, then it would be possible to load test the crane to say 1.15*load and still be under 100 % of chart. If a spreader bar must be load tested to say 1.25*SWL, then I recommend that the bar be designed with added capacity so that the load testing will be at 100 % of the SWL.

Inspection Of The Boom Line:

When the regular monthly inspection of a crane is performed, I would recommend laying the boom down and looking at the boom line where it comes off the boom drum. This is the point on the boom line where the tension is normally the greatest, causing crushing and flattening of the strands.

Crane Adjustment:

I would recommend that a Senior Operator be delegated to operate every piece of equipment at least quarterly to make sure that it is in operational adjustment.

Lug Nut Inspection On Crane Carriers and Tractor-Trailers:

When I was with Jake's Crane and Rigging, we had several instances where the lug bolts failed and both dual tires flew off the axles. I was quite concerned about this as it could very quickly put the company in a large liability claim if one of the tires or load had hit an oncoming car or truck. I tried to develop a schedule for inspecting the lugs nuts for tightness but unfortunately I was not successful. I would recommend that you develop a schedule to avoid an accident and potential harm to the company and others.

TRAINING:

I would like to add one more element to the relationship of rigging and safety and that is training. The three must work together to provide safe and efficient rigging operations.

When I refer to the operating engineers in this section, I mean it to include the other crafts as well.

I love to train, especially when the students are receptive and are like little sponges. I have had the opportunity to help train a lot of Fluor's young rigging engineers and rigging foremen. It is a pleasure to see them grow in rigging maturity and confidence.

Mexico City Rigging Engineer:

One great training experience was when we trained a young graduate engineer from Mexico to be a Fluor rigging engineer. It all started in 1994 when Fluor bought one of the better construction companies in Mexico called ICA. The problem was that ICA would only sell 49 % of the company to Fluor, so Fluor had limited say in how the new company called ICA Fluor Daniel was ran, but they had a lot of liability. During the first two years, the new company had four major crane accidents, not counting the many smaller crane accidents that were not reported to Fluor. As a result of these four crane accidents, Fluor management decided that something must be done to stop these major accidents. So they sent a Vice President of Construction, my boss who was the Manager of Construction Technology and myself to Mexico City to meet with ICA Fluor Daniel management to see what could be done. As I was flying from LA, I went over the four accidents and decided that it wasn't going to be easy to solve this problem, as I knew that they didn't want some Gringos coming down to tell them what to do. But as the miles flew away, an idea slowly came to mind on how to solve the problem.

The next morning at 9 am, we all met in a large conference room. There were about 25 ICA Fluor Daniel mangers and the President seated around the room. The Fluor Vice President started off with an introduction of everyone and ended up stating why we were there. I am sure that most of them could speak English but by the time his remarks went thru a translator, it took about 1.5 hours for his presentation. My boss went next and took up the next 1.5 hours. We then stopped for lunch and then it was my turn to tell them about Fluor's rigging engineering department, how it could help them and to go over the accidents. As I got about 30 minutes in my presentation, I could tell that I was losing them as about half looked like they were asleep. So, I stopped and said "I have a proposition that I feel will be beneficial to both Fluor and your company. Why don't you send a young graduate engineer to our rigging engineering department in Irvine and let us train him for two years to be a rigging engineer. Then he could come back to Mexico City and start a rigging engineering office for you."

They didn't even wait for the translator to say a word but started talking among themselves. The buzz went on for about 15 minutes while we three gringos and the translator just waited it out. Finally the President asked me what would be our requirements and how much would it cost. I told them that we would require a young graduate engineer with a mechanical, civil or structural degree, one with good computer skills, one who could speak good English who was a self-starter and gave them the approximate cost. I told them that he would have full access to our rigging manuals, standard rigging drawing, procedures, and computer programs. I also told them that they could start sending their major crane lifts to Irvine and we would design then and that after about 6 months their rigging engineer would be able to do most of the work. Again the buzz started around the room and lasted for another 15 minutes. The President finally spoke and said they had decided to send two engineers to Irvine, one would be a senior construction engineer who would stay for six months training and the other one would be a young engineer who would stay for two years. Now the questions really started and we spent the rest of the afternoon going over the proposal. The attitude in the room had changed from hostile/defensive to a very positive questioning one. We didn't even use the translator after that.

And that is what happened. The training for the senior engineer was not too satisfactory because he did not speak good English and the young engineer spent considerable time translating for him. But the training results for the young engineer were outstanding. He returned to Mexico City after two years, started a rigging engineering department and the last I heard he had trained three rigging engineers on his own. The end of the story is that their Engineered and non-engineered crane accidents fell off to near zero, all because of the rigging engineering training of one graduate engineer.

Operator – Oiler Training Concept:

I love the operator–oiler training concept, but some times the training has a mixed out come. This was the case when my younger brother oiled for me. I was a little hard on him for two reasons, 1) I wanted him to learn how to take care of and to operate the crane the right way or at least the way I felt he should and 2) I didn't want anyone to think that I was carrying him because he was my brother. So we had our good days and our not so good days for about a year and then one day he backed the carrier into a 55 gallon barrel of curing compound when he was wiggling off of a lift pad. I shouldn't have said anything but I couldn't resist cautioning him. He jumped out of the carrier, looked me in the eye and said, "big brother, I am sick and tired of your two bit chicken shit advice, I quit". He caught a ride to the office and went home. I later heard that the Union Hall had sent him to large power plant at Page, AZ and that he was oiling on a 6 CY Lima dragline. It was about a year later on a Sunday afternoon that he called and we chit chatted for a little while. He finally said, "you know that this isn't strictly a social call" and I said I didn't think it was. He said that the main reason for his call was to apologize for the way he had acted during the time he was oiling for me. I told him he didn't owe me an apology because I was pretty hard on him. He said, no you weren't to hard on me, I just thought you were and I will tell you why: I oiled on a 6 yd dragline for about six months and then the operator had a heart attack. He told the superintendent to let me operate the dragline while he was recuperating. So I became the operator of the dragline and they gave me an oiler. And you know what? He was exactly like I was when I was oiling for you. I don't know how you put up with me for so long". Grant and I have not had an argument since that time. Several times over the years after that, he was the operator and I was his oiler and vice a versa.

Young Kent Goodman The Oiler:

I started out oiling for Howard on a 25-ton truck crane. He was an excellent operator and I learned a lot from him but he was from the old school where it was the feeling that an oiler wasn't allowed up in the seat of the crane for at least three years. I think this came from the old timers wanting to keep the crane operator pool small. I could stand on the ground and watch Howard in motion and could visualize every mechanical movement that he needed to do to perform a certain operation. But, he didn't give me the opportunity to gain the coordination and experience to actually operate the crane. I oiled for Howard for a little over a year and when the company bought a new crane, I opted to stay with the 25-ton crane with a different operator. Between him and a third operator on the 25-ton, I finally became the operator after a little over three years.

Operators, you can't afford to be like Howard and in some cases like me. As more cranes are coming available, we need all of the good operators we can get. You need to kindly and patiently put your arms around the shoulders of your oilers and train them in the art of operating a crane. One of the ways that we can help reduce crane accidents is if we produce competent and experienced operators. If we don't reduce the number of crane accidents nation wide, then the clients and the government will take steps to do so from their end. And you know what a disaster it usually is when the government steps in. Can you imagine how hard it is going to be to move in and make a lift on the Lyondell refinery in Houston in the future?

Oilers or apprentices, listen to your operator or trainer with an open mind. Don't be discouraged and negative about things that don't seem to make a lot of sense at the time. Know that they are part of the experience that you will need to become a good operator. So be patience and have a positive attitude. You need to do your part in the training process.

The Blacksmith

When my uncle Walter was a very young man, he went to work for Tanner Construction Company in Phoenix, as an apprentice to the blacksmith. This was back in the late 1920's when the blacksmith had to make most of the spare parts for the equipment, even for most of the new equipment. Mr. Tanner went to an equipment show in Los Angeles, which could have been the forerunner of the Las Vegas ConExPo. When he returned to Phoenix, he drove into the yard and backed up his pickup to the blacksmith shop. He was beaming from ear to ear and couldn't wait to show the blacksmith what he had purchased at the equipment show. He pointed out that he had a acetylene cutting torch and that it would revolutionize the way parts would be made from then on. In the pickup was a bottle marked oxygen very similar to the bottles we now use. But instead of a bottle of acetylene, there was a two wheeled cart with a contraption on it that produced acetylene. He fired up the acetylene producer, had someone bring him a piece of flat iron and proceeded to cut the piece of iron in to two parts. The blacksmith had the acetylene set unloaded and as soon as Mr. Tanner was gone, he moved it to the back of the shop and never used it all. But, Uncle Walter was intrigued by it and many nights when everyone had gone home, he played around with it, cutting strange shapes out of flat iron, etc. Well, to make a long story short, it wasn't long until Uncle Walter was the boss of the fabrication shop and the blacksmith worked for him. Moral of the story, change or get left behind.

Hazard Awareness Bulletin:

Even personnel not directly involved in rigging operations can be trained to look for unsafe crane and rigging operations. The hazard awareness bulletin shown below was posted in the Construction offices so that field engineers, mechanical engineers, Pipe Fitters, etc, could study it and as they were moving about the site, they could observe and report what they thought were unsafe rigging conditions. Sometimes, the things they reported were not significant but every one was looked into.

Hazard Awareness for Crane and Rigging Operations

In order to achieve our goal of "ZERO" crane and rigging accidents, **EVERYONE** on construction jobsites must be on the look out for common, easily observed conditions which signal improper crane and rigging use. It is every employee's responsibility to be aware of the following potentially dangerous crane and rigging operations. If any operation is observed where the answer is **YES**, please inform a supervisor **IMMEDIATELY!**

Is the crane standing near a trench or excavation?

Is the crane standing near enough to contact power lines, pipe racks or other objects during its normal movements?

Does it appear that the crane operator does not have control of the crane, i.e. the crane and hook movements are not smooth and coordinated?

Is anyone riding on the load or crane hook?

Does the crane's hoist line(s) appear to be out of vertical during operation?

Are lifting slings rigged at horizontal angles flatter than 45 degrees?

Is the crane noticeably out of level while operating?

Is the lift being made without fully extending the outrigger beams and jacks?

Are any outrigger pads or crawler tracks raising off the ground while the crane is operating?

Is there any structural damage visually apparent on the crane or rigging?

Has the crane been obviously modified by adding extra counterweight, etc.?

Is the rear of the crane tied down to increase capacity?

Is the lift being made without using any tag lines?

Please post on all bulletin boards at Construction projects.

QUIZZES:

I have attached three quizzes that are from my website but that I feel are worthy of discussion in this safety presentation. The reader can go to my website, www.maximumreach.com, to see the quizzes in detail and the answers.

The first quiz, number 15 on my website, shows how to correctly block the front tumbler of a crane, not to get increased lifting capacity but to obtain the lifting capacity listed on the chart.

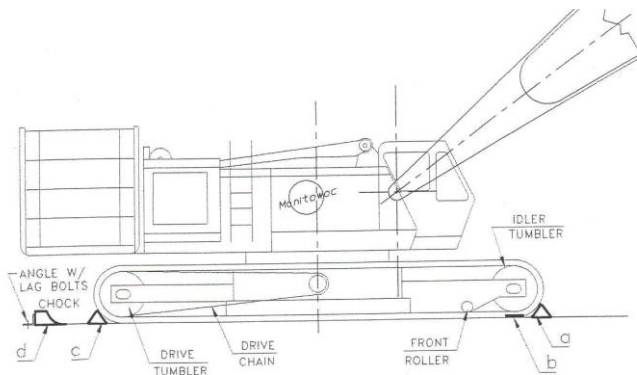

The second quiz, number 10 on my website, shows how to determine if a crane is starting to tip and explains the percentage of chart when doing so. It also contains a link to Ron Kohner's article on working in the twilight zone.

GIVEN:

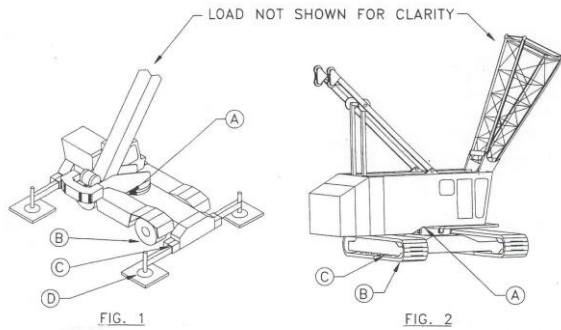

The third quiz, number 25 on my website, shows guidelines on how to determine where to set up a crane relative to a retaining wall or an excavation. I really like this quiz and spent some considerable time on formulating it because as was stated above, most crane accidents occur from tipping over or working out of chart or a combination.

GIVEN:

1. Outrigger Float Diameter = 24".
2. Boom Is 81' Long.
3. Total Load (Load Block + Rigging + Pipe) = 14,000 lbs.
4. Soil Is A Sandy Loam With A Bearing Strength Of 3000 psf (pounds per sq. ft.).

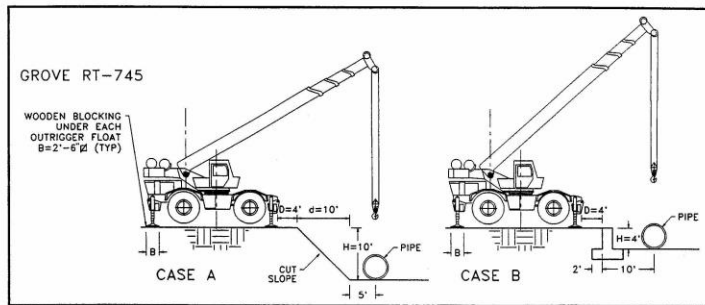

FIND:

1. Is the crane positioned far enough away from the shoulder of the excavation?
 Case A: Yes ___ No ___ if no, what should "D" be? ___ ft.
 Case B: Yes ___ No ___ if no, what should "D" be? ___ ft.
2. List five things to check for in regards to ground work prior to setting up a crane near a slope.
3. Is the outrigger blocking area "B" large enough?
 Case A: Yes ___ No ___
 Case B: Yes ___ No ___
4. In general, does the maximum outrigger loading occur at:
 A. Minimum radius with minimum boom & maximum load, or ___
 B. Extended radius with long boom & capacity load ___

MODELS:

Models are very useful for determining how a load will react during lifting. The model doesn't have to look exactly like the load being lifted; it only needs to be to some scale with the weight, the location of the lifting points and the location of the center of gravity in proportion to the actual load.

Cable Spool:

QUIZ 1

If the chock is removed, will the spool roll down the ramp?

YES _____ NO _____

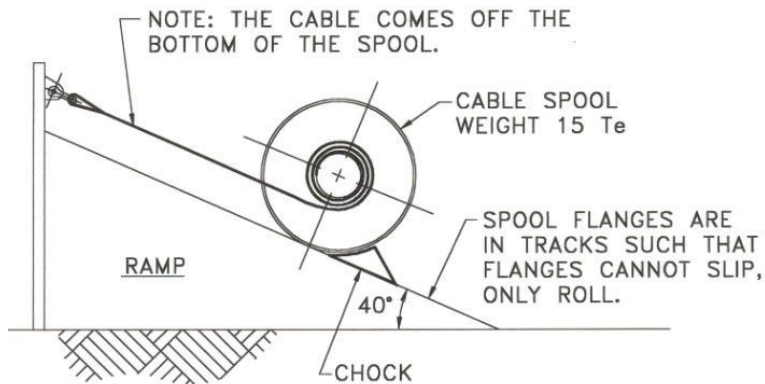

This photo shows a cable spool on a ramp with the cable tied off to a dead end. The question is asked will the cable spool roll when the chocks are removed? When I was in a static's lecture class of about 150 students at ASU, the professor had the Teaching Assistants (TA's) hand out this pop quiz to us. He told us that we had five minutes to look it and then just mark the box YES it will roll or the box NO it will not roll and then to pass them to the TA's at the center isle. The TA's pickup all of the pop quizzes, took them up to the podium where they and the professor started going thru them. When they finished, the professor looked up and called a student by name and asked him why he had marked the NO box. The student said he marked it no because he figured there wouldn't even be a quiz if it would roll. Another student gave another off the wall answer and then the professor called my name and asked me why I had marked the NO box. I told him that I knew that it would not roll but that I didn't know why. He asked kind of haughtily why I knew it wouldn't roll. I told him that many times I had rolled cable off a reel on to a hard road surface, and noticed that as the cable was unrolling, the dead end was slowly following along behind. If someone stood on the dead end, the flanges of the reel had to be slipped to continue unrolling the cable. The professor wanted an engineering answer but I couldn't give him one, so he gave me an E for effort. I like this quiz because it shows that things are not always as they seem. The next photo shows the engineering answer to the quiz.

ANSWER TO RIGGING QUIZ No. 1

No, the spool will not roll as shown, because the radius from its centerline to the outer layer of cable is less than the outside radius of the flanges. Imagine the spool rolling through 90 degrees from its present position. If 90 degree arcs for the cable and flanges are laid out parallel to the ramp, it can be seen that the resulting centerline positions of the spool at the end of each arc are not in the same place along the ramp.

If the spool was full of cable, then the radii would be the same and the spool would start to roll when the chock was removed. As the radius of the cable decreased due to cable being payed out, the spool would come to a stop on the ramp. This is assuming that the safe working load of the cable and the back stop were strong enough to resist the resulting momentum of the spool.

Note that the weight of the spool and cable nor the angle of the ramp have nothing to do with whether the spool will roll or not.

To prove to your self that the spool will not roll, place a reel of cable, a spool of electrical wire, or a yo-yo on a flat surface and start to slowly unwind it. Note that as the spool is unwinding, the end of the cable/string is slowly following along behind the spool. If someone stands on the end of the cable, the flanges on the spool have to be slipped in order to continue unwinding the cable.

The next two photos show a model that is similar to the quiz.

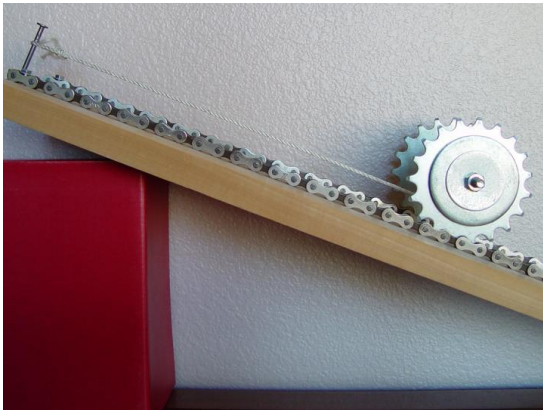

Lifting Below The Center Of Gravity:

The first photo shows a turbine being lifted with four slings connected below the CG. The question is asked, is this a stable lift?

Is this lift stable?

QUIZ 2

Beta=24 Deg.

Alpha=45 Deg.

Beta = 36 Deg.

Alpha = 33 Deg.

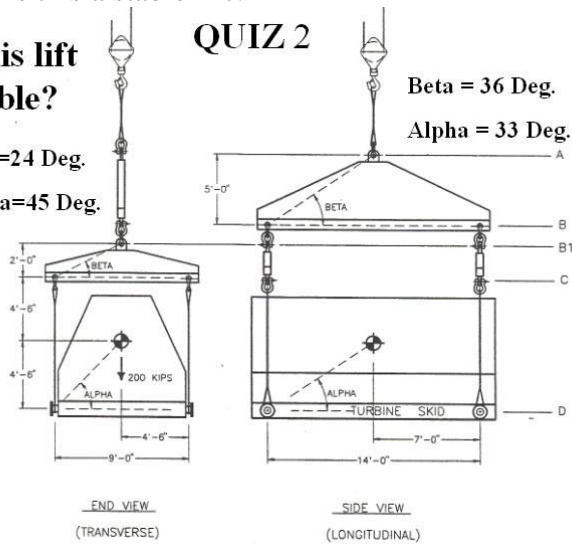

The next two photos show that the answer is NO, this lift is not stable in the transverse direction because the angle Alpha is greater than the angle Beta and marginally stable in the longitudinal direction.

ANSWER TO RIGGING QUIZ No. 6

The answer is no, this is not a safe lift. It is unstable against tipping in the transverse direction and borderline stable against tipping in the longitudinal direction.

This is because the angle Alpha below the center of gravity (CG) in the transverse direction is 45 degrees, and the angle Beta at the spreader bar is approximately 24 degrees. In order to be stable, Beta must be greater than Alpha.

For the longitudinal direction, angle Alpha is 32.75 degrees and angle Beta at the spreader bar is approximately 35 degrees. As Beta is greater than Alpha, theoretically, it is stable.

To better understand why the angle Beta at the spreader bar (or slings if they are being used above the spreader bar) must be larger than the corresponding angle Alpha at the CG in both the transverse and longitudinal direction, consider the following. Assume that the pick point "B1" in the transverse direction is actually located at "C" and centered between the shackle points. If the CG was located directly under the hook and could be kept there, then the load would be stable. But the location of the CG for a load is hard to calculate and is usually off by at least several inches to a foot. During lifting, dynamics of the lift, wind, different lengths of rigging, etc., tend to also shift the location of the CG. Therefore, if the CG is not under the hook as the load is lifted, the offset CG will cause the load to rotate away from the hook, and in so doing, the spreader bar and the skid platform will form a parallelogram as they rotate from the horizontal. As there is no resisting force against overturning or tipping, the spreader bar and skid platform will continue rotating into a more acute parallelogram until the slings bear up against the sides of the turbine. If the trunnions were located outside of the turbine frame, then the skid would turn up side down.

ANSWER TO RIGGING QUIZ No. 6, Continued

Consider one more situation where the skid is being lifted in the transverse direction without spreader bars, but with slings attached at the trunnions on the "D" line and connected to the pick points or hooks at a point below the CG. Also assume that there is no interference between the inclined slings and the turbine housing. As in the example above, there is no resisting force against overturning as the CG is located above the pick points or hooks & the skid is therefore unstable. Now, if the slings are lengthened until the pick points are above the CG, they provide a resisting force against overturning and the load will be stable.

So whether the slings are connected to the trunnions and run directly to the hook, or they start at the spreader bar and go to the pick points or hooks, they must form an angle Beta that is greater than the angle Alpha at the CG. If the CG is not centered between the skid pick points, then both Alpha angles in the transverse and both Alpha angles in the longitudinal must be computed and compared with the corresponding Beta angles.

Now the most often asked question is how much greater must angle Beta be than angle Alpha. Theoretically and on paper, if Beta is as great as say one degree larger than Alpha, the lift should be stable. But due to the dynamics of lifting, the CG location not always being known accurately, the slings not always matched for length, etc, it is recommended that Beta be at least 20 degrees larger than Alpha. In most cases this will be conservative but safe.

The next photo shows a platform supported by three spreader bars, two transverse and one longitudinal.

**AN EXAMPLE
SIMILAR TO
QUIZ 2**

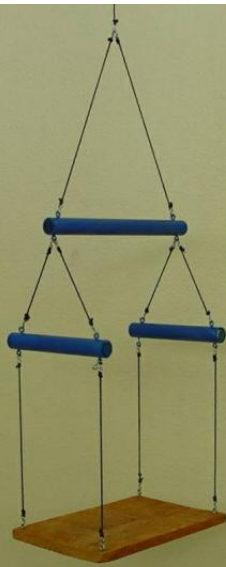

All it took to construct this model was a piece of board, string, one inch dia. PVC, screw eyes and S hooks.

The next photo shows the model with a four brick load resting on the platform suspended by two transverse spreader bars and one longitudinal. In this configuration, it is stable in both directions.

The angle "Beta" between the slings and the transverse spreader bars is approx. 60 deg.

The angle "Alpha" is approx. 49 degrees for four bricks



Note that the load of four bricks is stable

The next photo shows that when a five brick load is placed on the platform, angles alpha and beta are equal and the brick load is starting to turn over. Note the transverse spreader bars and the platform are starting to form a parallelogram. For a six brick load, the platform will turn over no matter which way the bricks are placed on it.

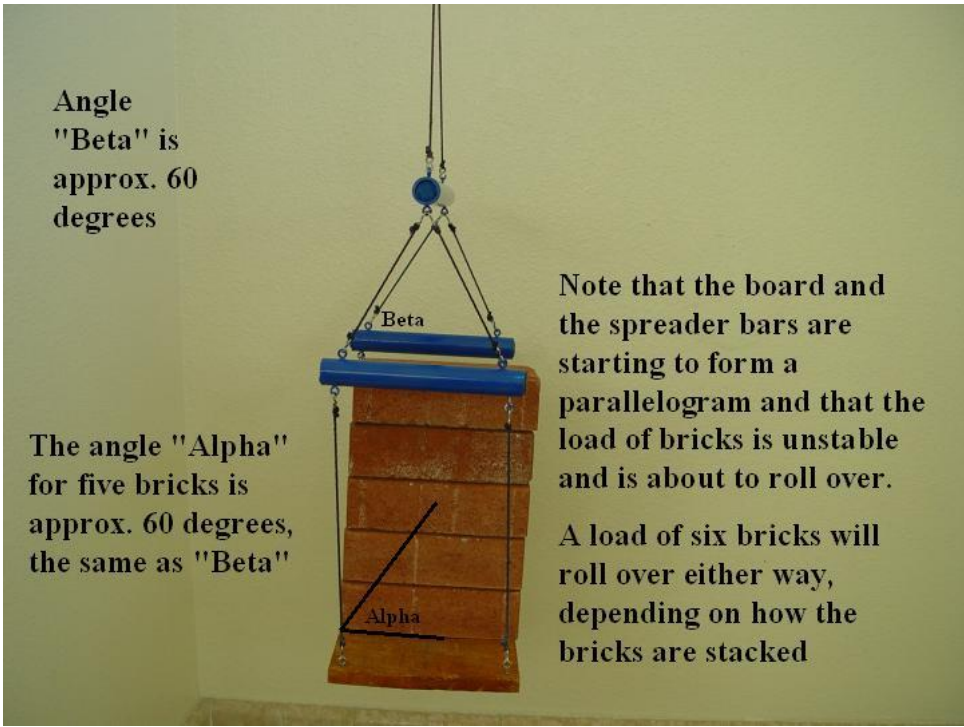

The next photo shows that a five brick load is stable in the longitudinal direction.

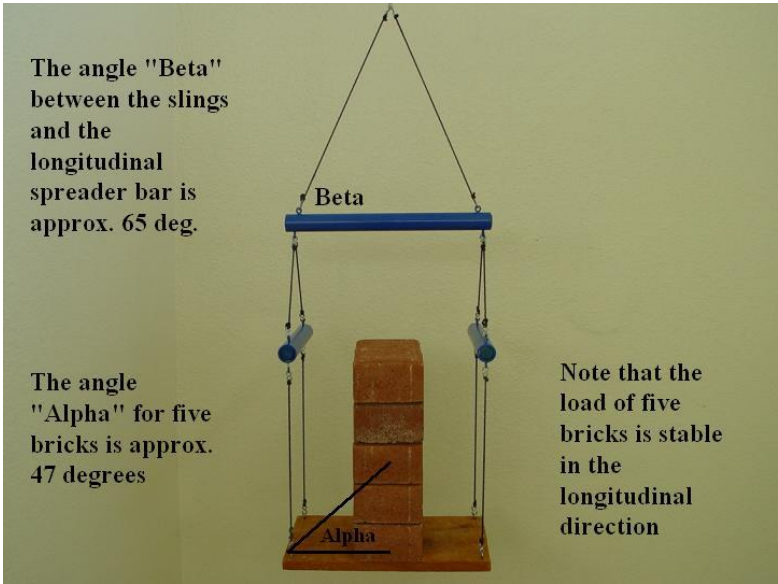

Setting An Overshot Line:

The next photo shows a large diameter pipe called an overshoot line being lifted from where it was fabricated on pipe stands. It was 48" in diameter with a 50' vertical run and a 50' horizontal run and weighed 50 kips. Johnny, the Indonesian rigger in the foreground was my rigging foreman. I had been

working with him for about six months and in all of this time, I couldn't get him to measure the radius for his lifts with a tape or level the cranes with a four-foot carpenter's level. He told me that Mr. Snody didn't make him do it and I told him that Mr. Snody was in Indonesia and not here. At the time of this lift, I was about to fire him and send him back to Indonesia to be with Mr. Snody.

We had a pre-lift meeting before we began hooking up the rigging and I went over the lift. One of the things I pointed out was that with the pipe in the initial pick position (IPP) that the 1" diameter sling going from the hook to the end of the horizontal run would be slack on the ground. The 1" sling was located outboard from a 2" nozzle that would keep it from sliding toward the CG.

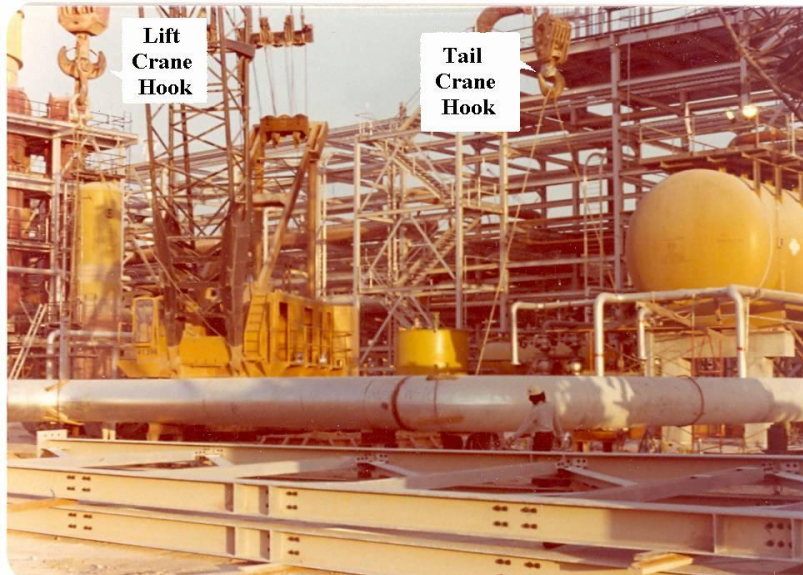

Johnny either didn't understand or wasn't listening because when we completed the hook up, he was very concerned that the 1" diameter line was lying on the ground. He came over to me and said something is wrong and pointed out the 1" sling. I told him that I had double checked my calculations and that as we up ended the overshot line that the 1" sling would get tighter and that when it was upended, the 1" sling would be tight and the bottom run of the overshot line would hang level.

Now Johnny didn't want to lose face as there were a lot of other crews watching to see if we were going to let the overshot line fall off the pipe stands when we were floating it. He was very nervous as the up ending began as I don't think he believed me that the overshot line would lift vertical off the pipe stands and then hang level. When the overshot line was plumb with the bottom run level, you should have seen the look on Johnny's face.

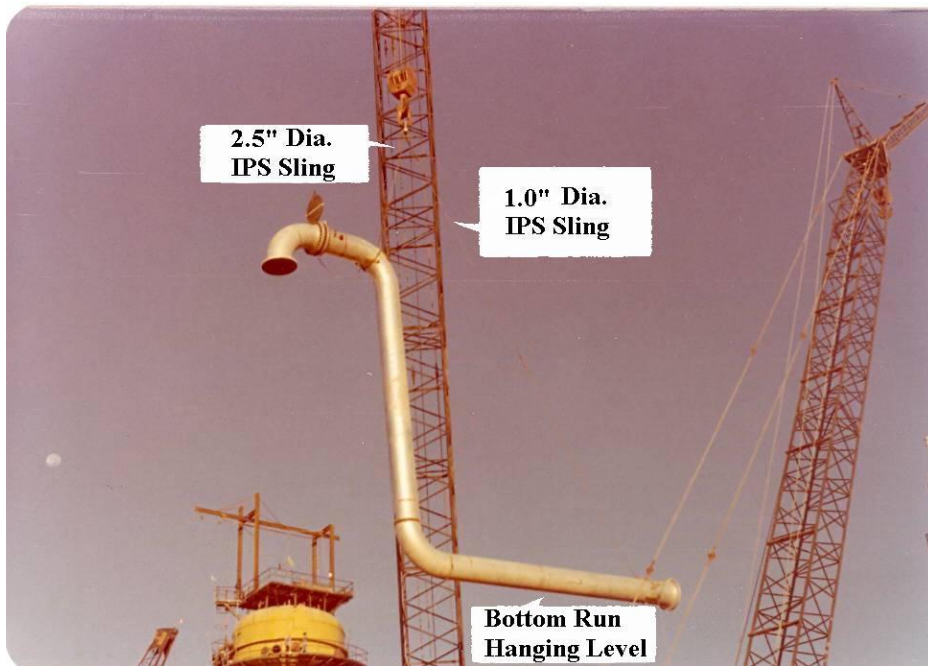

He had the crew swing the overshot line 180 degrees and set it so that the flanged end mated up to a flange on the top of a contactor and the level run rested on a saddle on top of a pipe rack.



As soon as the overshot line was set, Johnny came down off the pipe rack at a run and grabbed me by the hand and asked “how did you know that the 1” sling would tighten up and that the overshot line would hang level?”. I asked if he really wanted to know and he said yes. So I took him to my office and showed him my calculations for the weight and location of the CG. I then showed him my layout in the vertical where I plotted the location of the CG in both the X and Y directions. I then showed him how I started at the end of the level run and ran a sling up a 60-degree angle to where it intersected the vertical line thru the CG. This would be bearing on the hook. I then ran a sling down to the 90-degree elbow because it was a good place to connect to the overshot line without the sling slipping. I then showed him how I

calculated the tension in each sling and arrived at the sling diameters. And how I took moments to see what the reactions would be when the overshoot line was laying in the horizontal.

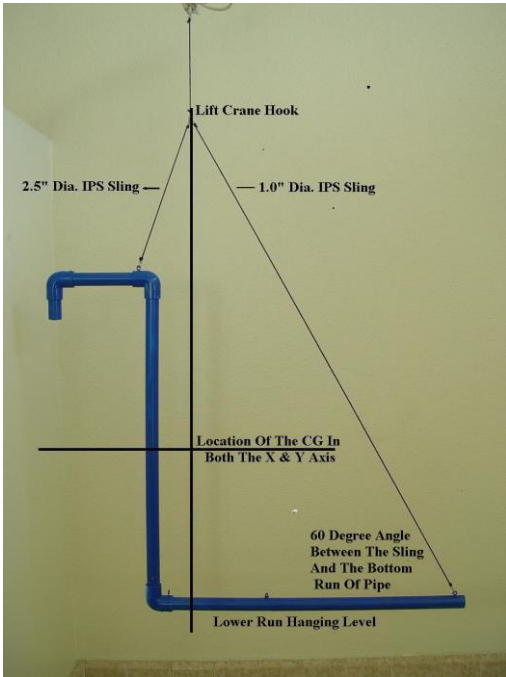

These calculations were to locate the tailing slings so the overshoot line would lift level off the pipe stands.

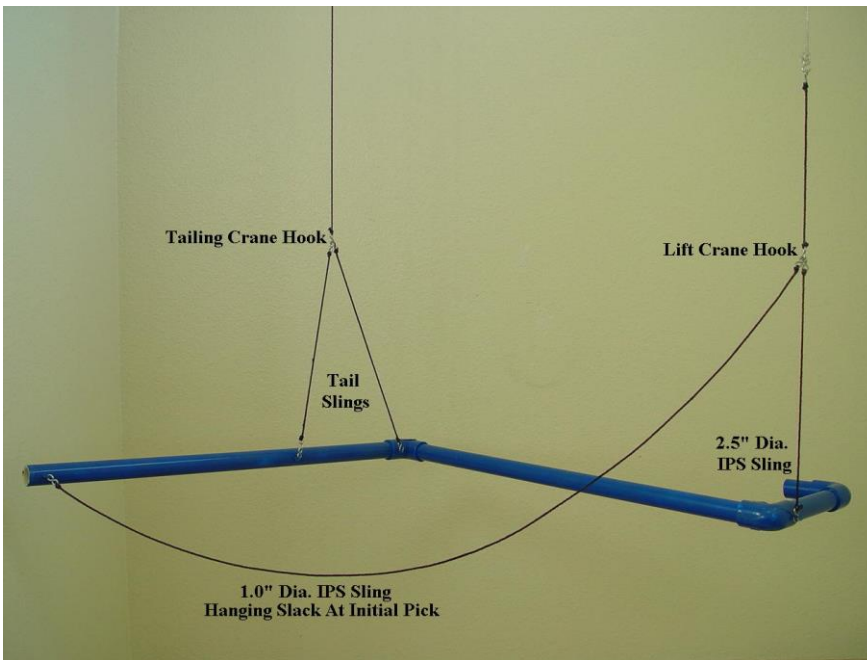

He didn't understand all that I showed him but he was very impressed and had me make him a copy of everything. From that day on, he did everything I ask him to. And the nice thing about this experience was that he never again said "Mr. Snody didn't make me do that".

15 years later as I was visiting a jobsite in Indonesia, I asked where the rigging yard was. I was given directions and told that the local rigging superintendent was expecting me. As I got out of my car at the

rigging yard, a man came running out and gave me a big big hug. You guessed it, it was Johnny. By then his riggers and operators had gathered around us. He turned to them and started talking in Indonesian, pointing first to himself, then to me and then using his hands in an upending motion. So I knew that he was telling them about the lift we had made years earlier in Saudi Arabia.

RIGGING ACCIDENTS:

The first photo states that normally, rigging accidents are not caused by one factor along. But if several factors line in a negative direction, Murphy will make sure that an accident will happen.

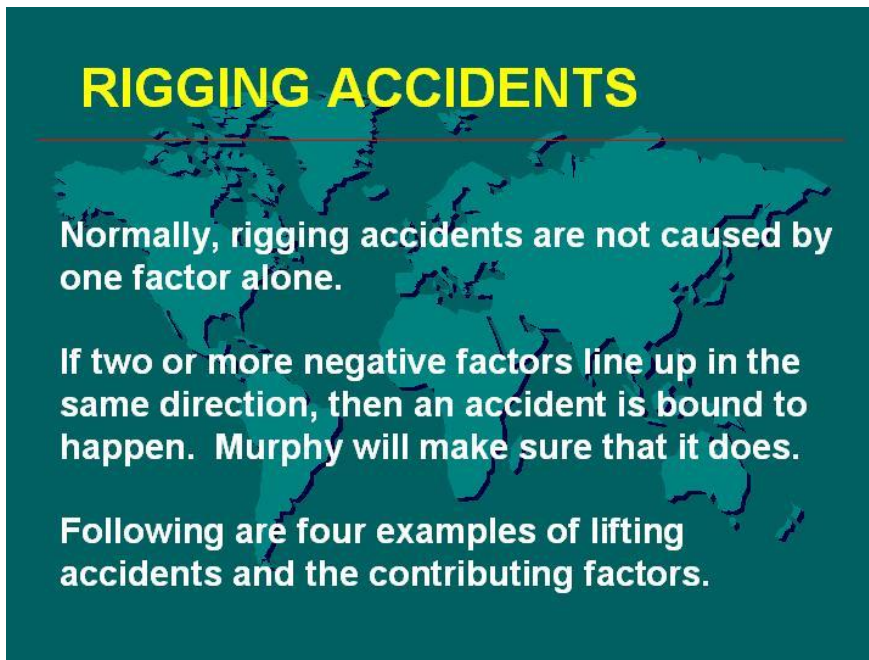

Following are four accidents that I would like to talk about.

This photo shows Accident 1 and the factors that lead up to a crane accident where a 50 Te hydraulic crane was being used to install a luffing jib on a 400 Te hydraulic crane. This was the accident that brought about the Fluor Crane and Rigging Procedure.

FIELD RIGGING ACCIDENT # 1

50 Te Crane turned over on top of a 400 Te crane during the installation of a luffing jib. One rigger was seriously injured

CONTRIBUTING FACTORS:

1. The rigging crew partied late the night before the accident
2. The crew did not have a clear work plan
3. The crew thought the weight of the aux. drum assy. was 1 Te. It actually weighed 5 Te
4. The LMI of the 50 Te crane was inoperative due to a jumper wire installed by the operator
5. The radius of the 50 Te crane could have been reduce by swinging the house of the 400 Te crane 180 degrees

NOTE: Boom missed a live hydrogen line by about 1'

This photo shows the original location of the auxiliary drum that was to be installed on the 400 Te crane, the intended location, its location after the accident and the live hydrogen line that boom missed by about a foot.

50 Te Crane turned over on 400 Te crane

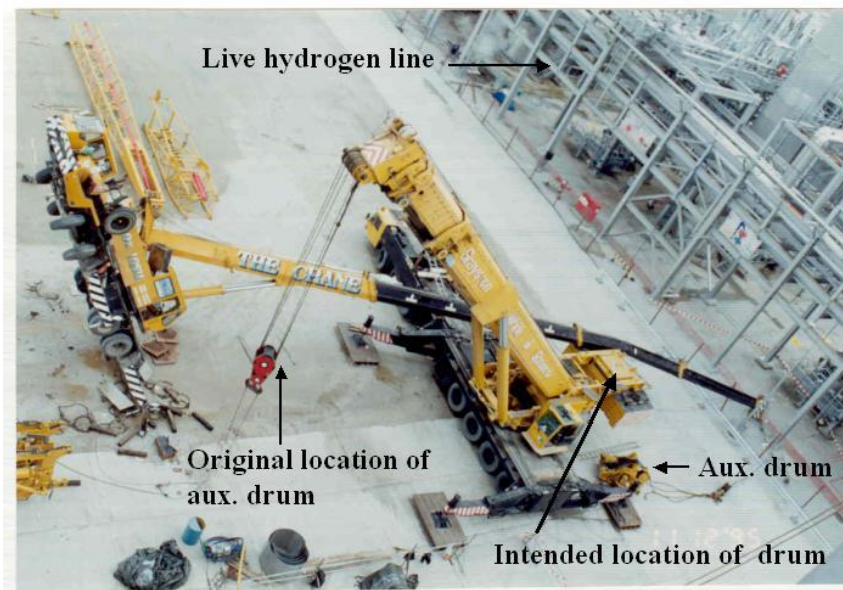

The next photo shows Accident 2 and the factors leading up to the accident where a boom dropped on a Link-Belt LS-718 ringer owned by a heavy lift contractor (HLC).

FIELD RIGGING ACCIDENT # 2

BOOM DROPPED ON A LINKBELT LS-718 RINGER OWNED BY A HEAVY LIFT CONTRACTOR (HLC):

- The HLC was asked to make a long radius load test
- This was done to proof the assembly of the crane
- A 60 ton steam drum was used as a test weight
- A HRSG module was parked next to the crane
- Boom dropped before the test radius was reached
- No one was injured

CONTRIBUTING FACTORS:

- a) The wrong Becket was used to dead-end the boom line
- b) The erection crew was in a hurry to complete the assy. and did not install a cable clamp on the pig tail

Prior to the accident, the Fluor Construction Manager for the site called me and said it had come to his attention that the contract with the HLC did not include a load test and he wanted to know what I thought he should do about it. I told him that it would probably cost the job about \$30,000 to have the HLC perform a full load test, but an alternative would be to require them to do two things. One would be to provide documentation that they had lifted a vessel of similar weight in the last six months with the same crane configuration. Two would be to have them perform a long radius load test with a load of about 50 tons. This load test would be to just test assembly of the crane. He said the first thing that they would lift was a 60-ton stream drum and that we could use that. So I figured out the radius that they would have to boom out the steam drum for 100 % of chart and then instructed them to perform a full function operational test. The field and the HLC agreed and set the load test for the next day. We received a phone call the next day that the boom of the ringer had dropped due to the boom suspension wire rope slipping out of the dead-end becket.

This photo shows the boom of the LS-718 buckled on the ground and laying on top of the steam drum.



360 ton Ringer crane accident

This photo shows details of the boom suspension. The accident investigation determined that the correct wedge for the becket could not be located so the HLC used another one and did not put a safety cable clamp on the pig tail of the wire rope.

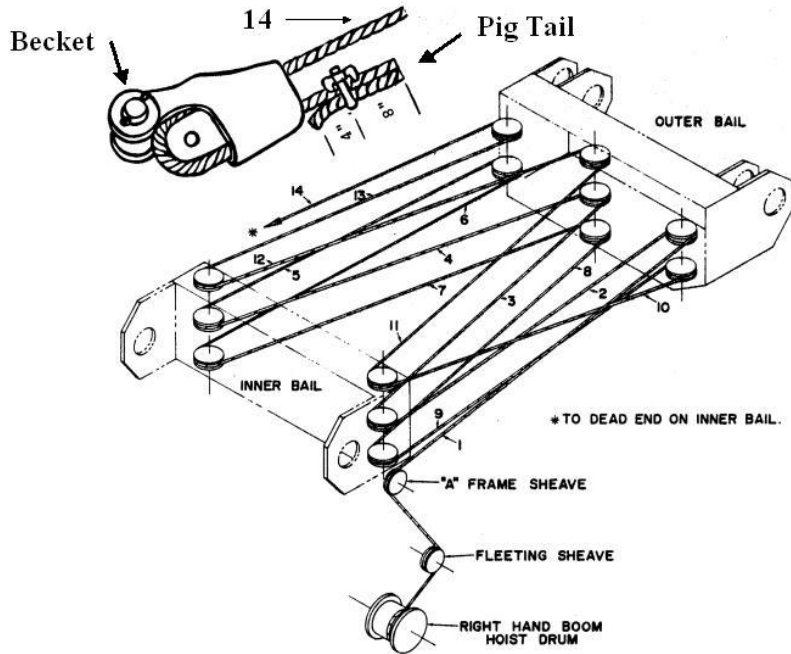

This photo shows the boom draped over an HRSG unit that had been staged to be lifted right after the load test. It is always a good idea to keep the area clear until after the load test.



The next photo shows Accident 3 and the factors that led up to the accident.

FIELD RIGGING ACCIDENT # 3

BOOM BUCKLED LIFTING A TOWER:

1. A 125 ton truck crane was lifting a two section electrical transmission tower. The pick point was just above the connection
2. Just as it was upended, the the bottom section fell off, moving the location of the CG above the lift point
3. The top section did a 180 degree loop and twisted the boom off the crane. No one was injured
4. CONTRIBUTING FACTORS:
 - a) The rigging crew relied on a pressed fit and friction to hold the two sections together.
 - b) The sections should have been welded or bolted together

This photo shows an existing tower with the same configuration as in the accident.

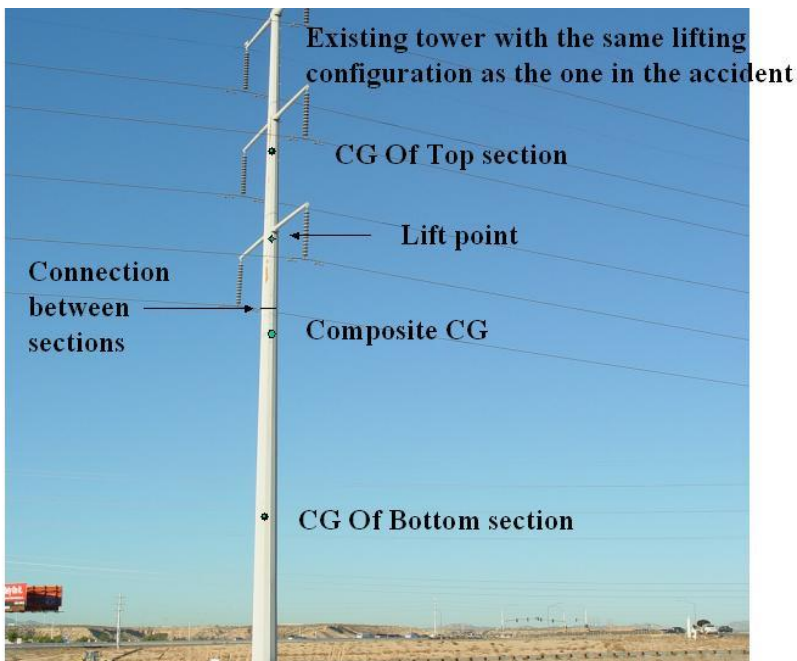

This photo shows the bottom half of the tower laying on the ground and the top half laying on the crane and boom. As the tower was almost in the vertical, the bottom half slipped out of the top half, resulting in the CG suddenly being above the lifting point. The top section did a 180-degree loop and twisted off the boom. Luckily, no one was hurt. This crane was on rental to the contractor constructing the towers, so he

had to continue his monthly rental until the crane was fully repaired and returned to the crane rental company.



The next two photos show Accident 4 and the factors that led up to the accident at the Miller Park Stadium.

FIELD RIGGING ACCIDENT # 4

BOOM BUCKLED AT MILLER STADIUM: CONTRIBUTING FACTORS:

1. A 100 ton roof section was combined with a 350 ton roof section as the job was behind in schedule.
2. The lift was not started until late in the afternoon. This meant that the pressure was on to complete the lift before dark.
3. There was a strong wind blowing and the rigging supervisor did not compute the wind pressure acting on the large sail area of the load and therefore did not know the actual wind force that was side loading the boom.
4. The rigging plan was not followed as the load was lifted over a higher point of the stadium than was originally planned for the lift.

FIELD RIGGING ACCIDENT # 4

5. The rigging crew was complacent because they knew that they had a crane with a lifting capacity of 1500 tons and they were only picking 450 tons
6. The technical capabilities of the rigging crew were suspect, as they did not properly plan for safety. All personnel were not cleared from the area within the fall radius of the boom and jib.

Three Ironworkers died when the man basket they were riding in fell about 150'. They were within the fall radius of the boom on the Transi-lift.

This video can also be found by going to [YouTube.com](https://www.youtube.com) and searching for "Crane accident kills three at Miller Park"

The video clip shows a July 1999 crane accident where the boom collapses on a Lampson Transi-lift, LTL 1500, while lifting a 450-ton roof segment for the Miller Park Stadium in Milwaukee. The crane was configured with 540' of boom and jib and had a maximum capacity of 1500 tons. Again, there is not just one factor that causes a crane accident and this accident was no exception. The accident investigation team determined that the following factors lead up to the accident:

1. A 100 ton section plus a 350-ton section were combined into the 450-ton lift as the project was behind schedule
2. The lift was not started until late in the afternoon. This meant that the pressure was on to complete the lift before dark
3. There was a strong wind blowing and the rigging supervisor did not compute the wind pressure acting on the large sail area of the load and therefore did not know the actual wind force that was side loading the boom. A side load of 1% is the maximum allowed.
4. The rigging plan was not followed as the load was lifted over a higher point of the stadium than was originally planned for the lift
5. The rigging crew was complacent because they knew that they had a crane with a lifting capacity of 1500 tons and they were only picking 450 tons
6. The technical capabilities of the rigging crew were suspect, as they did not properly plan for safety.

The reference to safety in number 6 stems from the fact that all personal were not cleared from the area within the fall radius of the boom and jib. In the video, you will note that a 200-ton crane with a blue boom, blue jib and man basket was located to the left of the LTL 1500. Three men were in the man basket waiting to secure the roof section once it was in place. Watch carefully during the collapse of the boom on the LTL 1500 and note that as it fell, it first hit the jib and then the boom on the 200-ton crane causing the man basket to fall and killing all three men in the basket. This video can also be found by going to [YouTube.com](https://www.youtube.com) and searching for "Crane accident kills three at Miller Park"

One more thing to note here is that Lampson leased the transi-lift "bare", but loaned the crane crew to Mitsubishi. The crew was on Lampson's payroll and they in turn invoiced Mitsubishi for the hours that the crane crew worked. Lampson also engineered the lifts, prepared the drawings and prepared the load charts. The Lampson rigging superintendent flagged the lifts, completed the critical lift plan, conducted the prelift meeting, supervised the rigging hookup, supervised the attaching of the auxiliary counterweight to the load and checked the ground conditions and level of the crane. It was decided by the court that he had the authority to stop the lift, but didn't. Lampson was fined \$131,300 by OSHA and had to pay

\$5,000,000 to the families of the three Ironworkers in a wrongful death suit. So, whether it is a “bare” or an O&M rental, we have to be very diligent in making decisive decisions during a heavy lift. If something is wrong, we must say **STOP** the lift.

Boy Scout training:

I recently had the opportunity to be the engineering merit badge counselor for the Las Vegas district of the BSA. I thought you would be interested in the examples that I came up with to show the boys some engineering concepts and to try to interest them in becoming an engineer. The examples show how construction material can be efficiently used on the job.

The first photo shows a section of a 1” diameter pipe and a 2” diameter pipe and asked the question: How many 1” pipes would it take to equal the same cross sectional area as the 2” pipe. The answer is four. It is calculated as follows where Area A = Pi*radius squared = Pi*r².

$$\text{Area of a 1” pipe} = 0.5^2 * \text{Pi} = 0.25 * \text{Pi}$$

$$\text{Area of a 2” pipe} = 1.0^2 * \text{Pi} = 1.0 \text{ Pi}$$

NAME: _____

GIVEN:

The sketch below:

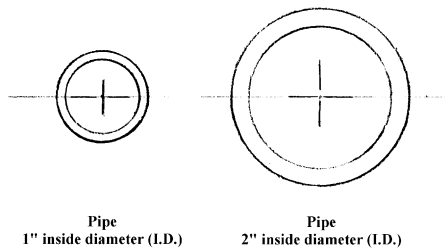

Remember, the formula for the area of a pipe is:

$$A = \text{PI} * r^2$$

= 3.14 times the radius squared

CALCULATE:

Calculate the number of pipes with a 1” inside diameter (I.D.) that would be required to equal the same cross sectional area as a pipe with a 2” I.D.

$$\text{Area for a 1" pipe} = (0.5^2) * \text{PI} = 0.25 \text{ PI}$$

$$\text{Area for a 2" pipe} = (1.0^2) * \text{PI} = 1.00 \text{ PI}$$

The next photo shows a section of a 0.25” diameter steel rod and a 1.0” diameter thin wall conduit and asks the question: Which has the greatest strength where each of them has a cross section of metal equal to 0.15 sq. inches.

NAME: _____

GIVEN:

The sketch below:

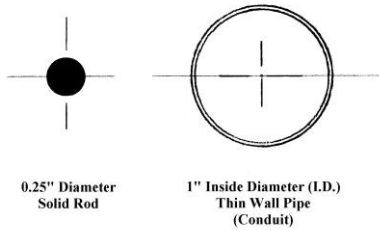

DEMONSTRATE:

Demonstrate which has the greatest strength as a beam, a 0.25" diameter solid rod or a 1" diameter pipe (a piece of conduit) where they both have approximately the same cross-sectional area of metal ie, 0.15 sq. inches.

The next photo shows the 1/4 " rod suspended between two barrels with a two brick load. Note that it has a large deflection, very near the yield point.

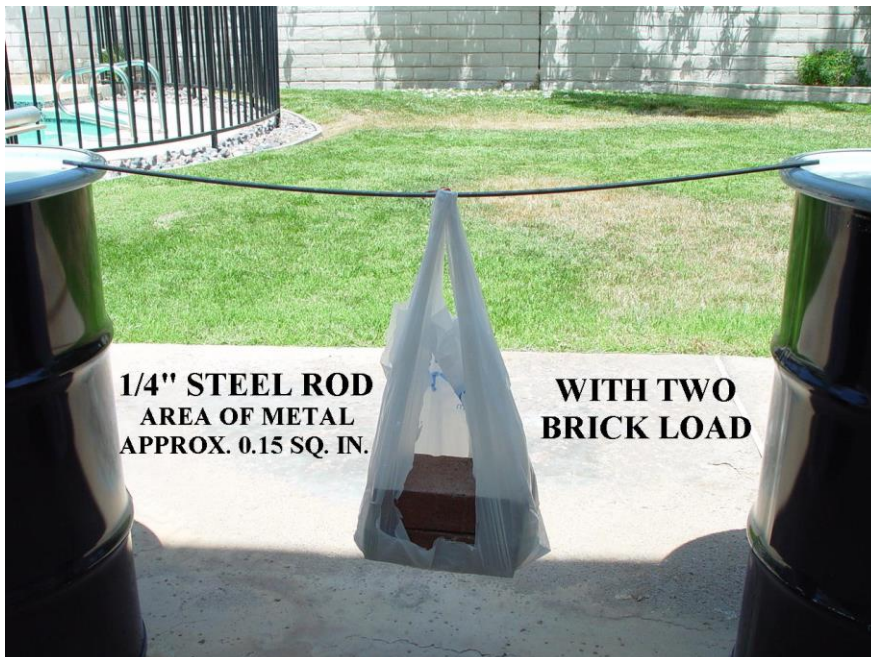

The next photo shows the 1" conduit with the same load and zero deflection.

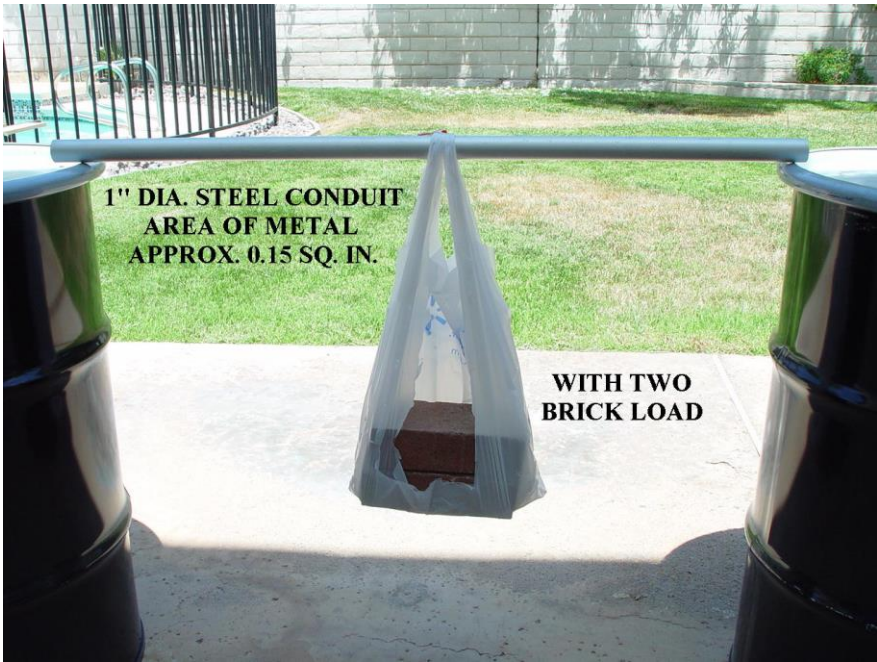

The next photo shows a yard stick suspended between two barrels with a two brick load. Note that the yardstick has massive deflection, again very near the yield point.



The next photo shows a plank suspended across a stream with a one-rooster load. Note that he is very self confident but the hens are holding back to see if it is going to hold him up. I think some of the hens would be glad if he fell in.



The last photo shows a yard stick bent into an arch. Note that for a two brick load, that there is zero deflection. Also note that the horizontal member is thru the sack but is not carrying any load. The rooster could have used this configuration on his bridge across the stream.



SUMMARY:

I hope that if you haven't gotten anything else from this presentation, that you will remember the following:

1. Be passionate about your work
2. Be passionate about safety
3. Be passionate about training

THE END:

Mike Goodman The Oiler: (Need to end this presentation with a chuckle)

Have any of you worked closely with a relative? It is not easy working closely with a relative, say as operator-oiler, etc. I want to tell you of an experience I had working with my son Mike. When he turned 18, I was working for Peter Kiewit Sons' Company and managed to get him into Local 428, oiling for me on a 60 ton B&E. At this time, we had just finished driving all of the piling for the pier footings, pouring the abutments, piers, etc., for a bridge. A steel fabrication company in Phoenix had the contract to fabricate the bridge beams and set them. They elected to rent our crane O&M to set the beams. On the appointed morning, we set the crane up on the South abutment per their instructions. The Ironworker crew and floats loaded with diaphragm steel, bolts, etc, arrived shortly thereafter.

Danny, the Ironworker foreman, held a toolbox safety meeting as soon as everyone was assembled. After the meeting, Danny asked the Ironworkers to stay, as he wanted to give them some final instructions. Soon after, they started unloading the floats. As I swung a load to the waiting Ironworkers, I noticed that they sort of scattered until the load pretty well landed itself. This went on for the first hour with Ironworkers scattering on both the hook up end and the landing end. Now as you know, this is enough to make you lose your self-confidence. I decided that I didn't want to have this go on for the expected three days of beam setting, so I jumped off the crane and walked up to Danny and asked him what was going on and explained my dilemma. At first he said nothing was wrong but he wouldn't look me in the eyes and he was digging a hole in the ground with the toe of his right boot. I told him this was serious and if there was a problem then we needed to solve it, ie, they could bring in their own operator if they didn't trust me. Danny finally stopped kicking the ground and looked me in the eyes and said that when he talked to his Ironworkers that Mike stayed with them. When he finished talking to them, he asked if anyone had anything to say and none of his Ironworkers did. But, Mike spoke up and said "you had better keep our good eye on the operator because he is a wild man".

I let that sink in for a minute and then asked Danny if he know who Mike was. Danny said he didn't and I told him that he was my Son. Danny started smiling and said, we have been had, haven't we? I said yes, you have, but I will take care of him. Danny said no, let us take care of him and they did. They worked his tail off and pulled every prank imaginable on Mike and he was very glad to see them leave at the end of three days.